

# ACTUATED VALVE

# KITZ 10K Compact Ball Valves

## Valve Design Features

- Convenient size range from 1/4<sup>B</sup> through 2<sup>B</sup>.
- Integral actuator mounting pads, which enable easy mounting or dismounting of actuators for speedy maintenance.
- Tight contact between PTFE ball seats and high-precision-machined balls for leakage-free service.
- Stems, made of high-strength brass, are used for a long service life.
- Choice of materials: Stainless steel for corrosion-resistant service, or brass and bronze for general W.O.G. service.

## Valve Design Specifications

Threaded ends:	JIS B 0203
Union ends:	JIS B 2301
Maximum service pressure:	1.0 MPa
	TKE, TKVE & TKSE for 3/4 <sup>B</sup> and larger, 5/10UTWE: 0.5 MPa

## Ball Valve Design and Applications

KITZ Fig.	JIS Material	Port	Bore*	Neck	End connection	Applications	Electric Actuator	Pneumatic Actuator
TE	CAC406	2-way	S.B.	Short	Threaded	On-off control of water, oil, and gas.	EA EAB EAL EALB ED** EAE***	Type C & CS (FBS)
TFE	C3771BE or CAC406		F.B.					
TLE	CAC406	Horizontal 3-way	S.B.	Long	Threaded	Insulation for thermal isolation.	EA EAB EAL EALB ED** EAE***	Type C & CS (FBS)
TNE								
TGE		Long	R.B.	TUE with insulation for thermal isolation.				
TUE					Vertical 3-way	S.B.	Short	Threaded
TLUE	2-way	R.B.	Short	Threaded				
TKE					Chrome plating C3771BE	Vertical 3-way	S.B.	Short
TKVE	CAC406	2-way	S.B.	Short				
TKSE					Vertical 3-way	R.B.	Short	Threaded
TNVE	SCS14A	Horizontal 3-way	S.B.	Short				
UTE					2-way	R.B.	Short	Threaded
UTFE	Vertical 3-way	F.B.	Short	Threaded				
UTNE					SCS13A	2-way	F.B.	Wafer
UTGE	SCS14A	Vertical 3-way	R.B.	Threaded				
5/10UTWE					SCS14A	Vertical 3-way	R.B.	Threaded
UTVE								

\* Bore design: F.B.=Full bore, S.B.=Standard bore, R.B.=Reduced bore to API 608.

\*\* ED Series are available only for TE, TNE, UTE, UTFE, UTGE and 5/10UTWE ball valves.

\*\*\* EAE Series are available only for TE, TNE, TUE, TKSE and UTE ball valves.

## Applications

Automated on-off or three-way flow control in HVAC service handling water, oil, gas, and air (by brass and bronze valves) or in light-load industrial processes for pharmaceutical, fine chemical, petrochemical, food, beverage, textile, and other general industries.

## Precautions

- ① No application to fluids including powders, dirt, or sands.
- ②
  - High viscosity fluid, steam, or vacuum
  - Operational frequency higher than 10 times an hour
  - Velocity of 3 m/s or higher
  - Service with concern of an extraordinary pressure rise of line fluid or a variation of fluid temperature higher than 80°C.
  - For voltages other than the KITZ standard specification, contact KITZ or its local distributors for technical advice on application to the following:

## PTFE Seat Pressure-temperature Ratings

### Valve: TE·TFE·TLE·TNE·TUE·TLUE UTE·UTFE·UTNE·5/10UTWE

- Fluid: water, oil, or gas (unfrozen)
- Ball seat: PTFE (Standard)
- O-ring: FKM (Standard)

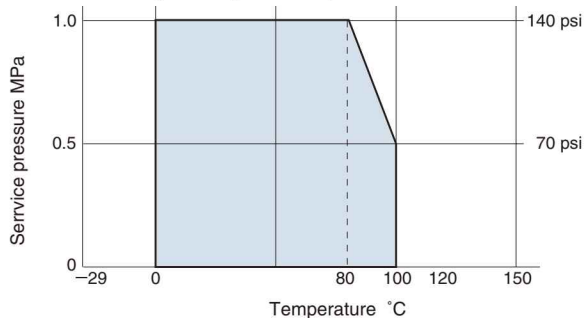

### Valve: TGE

- Fluid: water, oil, or gas (unfrozen)
- Ball seat: reinforced PTFE
- Gland packing: Flexible graphite + PTFE braided packing

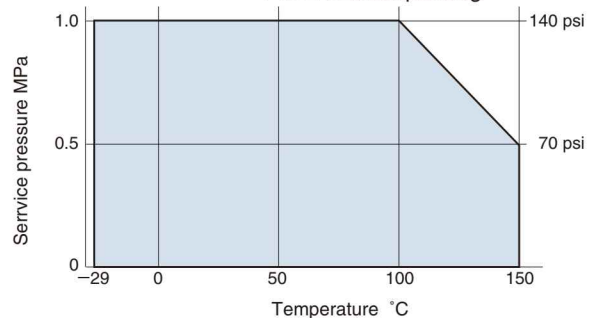

### Valve: TE·TFE·TLE·TNE·TUE·TLUE UTE·UTFE·UTNE·5/10UTWE

- Fluid: water, oil, or gas (unfrozen) or saturated steam
- Ball seat: reinforced PTFE (Option\*)
- O-ring: FKM (Option\*)

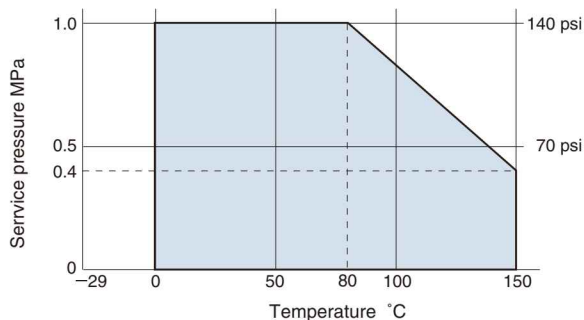

### Valve: UTGE

- Fluid: water, oil, or gas (unfrozen)
- Ball seat: reinforced PTFE
- Gland packing: Flexible graphite + PTFE braided packing

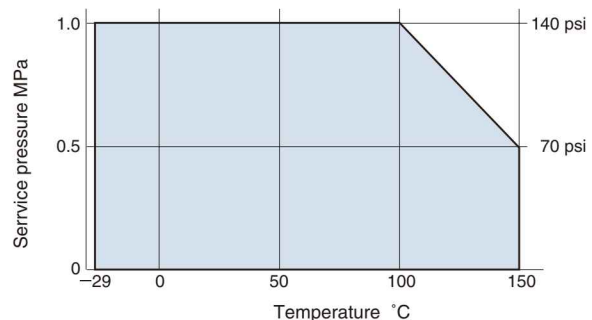

\* Specify these materials in your order for the P-T ratings covered by the graph shown above, except for 1½<sup>B</sup> and 2<sup>B</sup>. Standard materials are only available for these sizes.

- Note:**
- Please refer to our website ([www.kitz.co.jp](http://www.kitz.co.jp)) or contact KITZ for PTFE pressure-temperature ratings of TKE, TKVE and TKSE.
  - Serviceable ambient temperature depends on the design of actuators. Refer to the information given for each of actuators introduced in this catalog.

## Actuated Valve

### KITZ Three-way Compact Ball Valves: Change in Flow Directional Form

KITZ horizontal three-way ball valves are used primarily for a quick change in the flow direction. Furthermore, three-way ball valves can be used for simplification of piping systems, as shown in Fig. 1.

KITZ Figs. TNE, TNVE, TKVE, UTNE, and UTVE three-way ball valves are provided with an L-port and double face seating design for achieving a change in the flow direction between Forms 1 and 2. It should be noted if the line pressure of the closed bore is higher than the open bore, slight fluid leakage may occur from the closed bore. (Fig. 2)

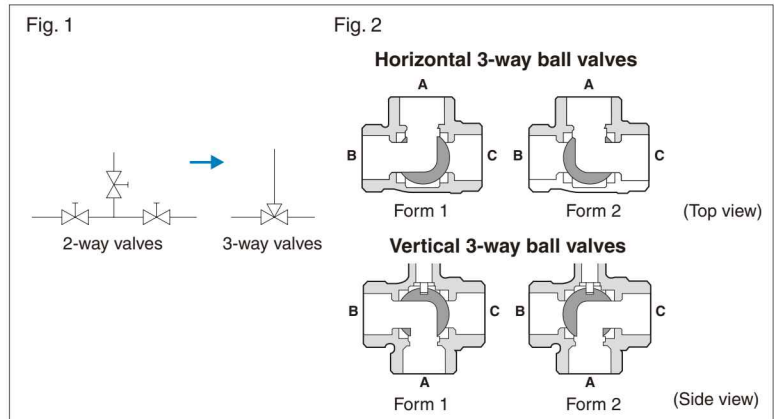

### KITZ 3-way Compact Ball Valves: Flow Directional Form

Shipment shall be made with the flow directional form fixed as illustrated here. (Fig. 3)

**Location of cord connectors** (top view):

Horizontal 3-way: Size 1 & 1.5: Right hand side  
 Size 2: Diagonally forward right  
 Vertical 3-way: Size 1: Right hand side  
 Size 2: Diagonally forward left

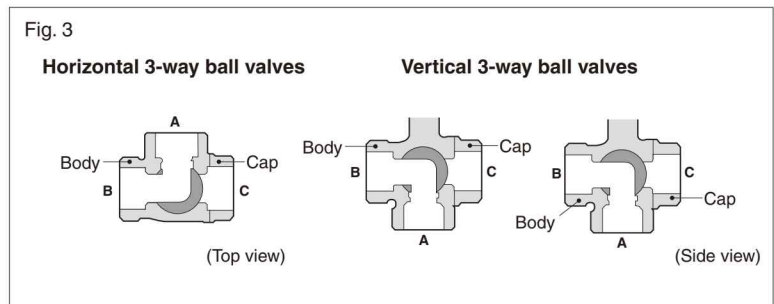

### KITZ KELMO® Electric Actuators: EA and ED Series

#### General design features

- Compact size and light weight with die-cast aluminum housing and powerful miniature motor for economy and handling ease.
- Simple mechanism with minimized number of component parts for high durability and trouble-free service.
- Free from concerns common to conventional solenoid valves, such as water hammer, pressure loss, malfunction caused by jammed valve interior, and restricted flow direction.
- All-weather-type design for outdoor service.
- Availability of manual operation in the case of electric failure.
- Versatile applications by means of optional built-in relay circuit for parallel drive, terminal boxes, and 180° rotary mechanism for three-way flow direction.
- Safety provision to protect the motor from overheating damage caused by accidental overload.
- Factory-made actuator-to-valve assembly for off-the-shelf supply.



## KITZ KELMO® Electric Actuators

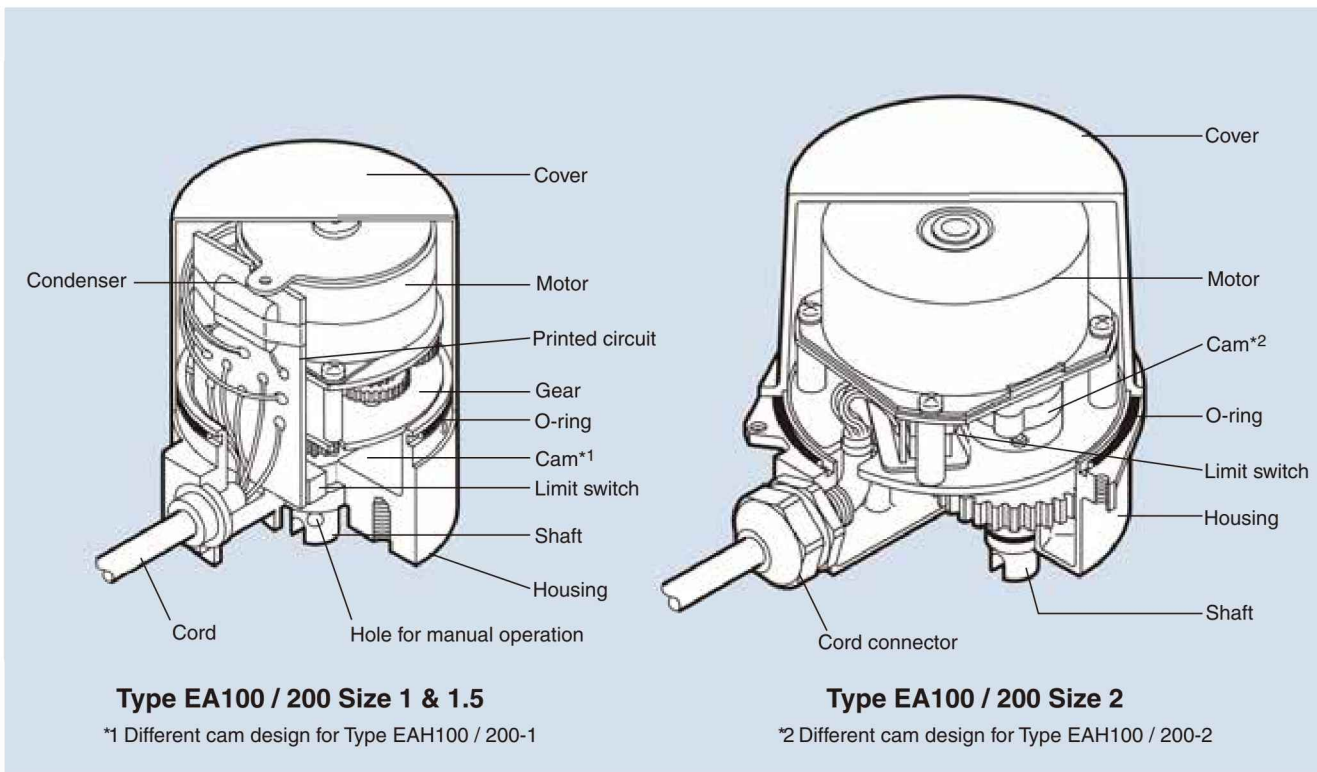

### Compact KELMO® actuators: power sources and functional features

Type of actuator		* Power source	Functional features
EA Series	EA100 / EA200	100 V AC 200 V AC (50 Hz / 60 Hz)	90° bi-directional rotation
	EAB100 / EAB200		90° bi-directional rotation / Terminal box
	EAL100 / EAL200		90° bi-directional rotation / Built-in relay
	EALB100 / EALB200		90° bi-directional rotation / Built-in relay / Terminal box
	EAH100 / EAH200		180° bi-directional rotation
	EAHB100 / EAHB200		180° bi-directional rotation / Terminal box
	EAE100 / EAE200	100 V / 200 V AC (50 Hz / 60 Hz)	90° bi-directional rotation / Spring-return
ED Series	ED12 / ED24	12 V / 24 V DC	90° bi-directional rotation / Parallel drive

\* Optional Specification (EA Series)

110 V AC (50/60 HZ)

115 V AC\* (50/60 HZ)

120 V AC (50/60 HZ)

230 V AC\* (50/60 HZ)

240 V AC (50/60 HZ)

\* EA100/200-1 only







# Actuated Valve

The adoption of common parts and part modularization have enabled flexible modification, which will widen the applications of the actuator.

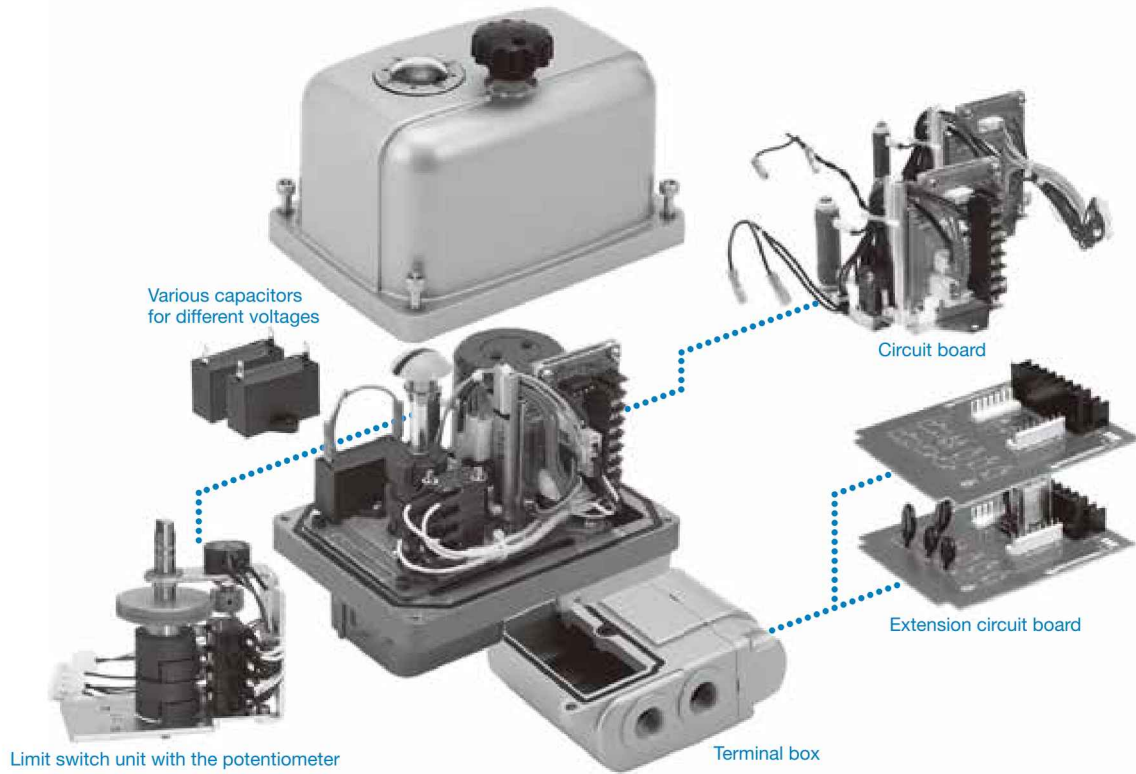

## Optional specification

### Power supply

**EXH EXS**

AC110 V 50/60 Hz

AC115 V 50/60 Hz

AC120 V 60 Hz

AC220 V 50/60 Hz

AC230 V 50/60 Hz

AC240 V 50 Hz

AC115 V 50 Hz, AC120 V 60 Hz, AC230 V 60 Hz, AC240 V  
Allowable fluctuation of supply voltage is limited within between minus 10% and plus 5% for 50 Hz.

### Relays

**EXH EXS**

Relays (on/off by a-contact) can be provided in the actuator by using extension circuit boards

### Limit switch specification

**EXH EXS**

Contact for Micro load (Minute electrical current)  
Two standard limit switches can be replaced by optional limit switches for micro load (minute electrical current)

### Potentiometer output

**EXH EXS**

135  $\Omega$  (Coil type)

500  $\Omega$  (Coil type)

The valve opening degree is indicated by resistance value.

### Auxiliary limit switch specification

**EXH EXS**

Two more additional limit switches can be added.

Switches for micro load application are also available.

Including four standard limit switches, total six switches can be used. (In case the potentiometer is used, four limit switches in total can be used at maximum.)

### Terminal box

**EXH**

G1/2 two conduit ports

G3/4 one conduit port

NPT1/2 two conduit ports

NPT3/4 one conduit port

M20 one conduit port

Terminal box with two G1/2 conduit ports is equipped as standard for EXS type.

For EXH type, the use of the terminal box will enable the actuator to connect cables without removing the cover and to extend the actuator functions by using optional circuit boards.

### Conduit port

**EXH EXS**

G3/4, NPT1/2, NPT3/4, M20



# Specification

High-speed type For ball valve	EXH100/200-1	EXH100/200-2	EXH100/200-3	EXH100/200-4	EXH100/200-5
Standard-speed type For butterfly valve and ball valve		EXS100/200-2	EXS100/200-3	EXS100/200-4	EXS100/200-5
Power Supply	100/200 V AC ±10% 50/60 Hz				
Output Torque (Nm)	9.8	49	196	588	1000
Rated Current (50/60Hz) (A) *1	100 V AC	0.65	1.2	2.8	2.8
	200 V AC	0.35	0.35	0.6	1.5
Motor Type	Reversible				
Motor Output (W) (Rating)	13/16	13/16	26/31	72/85	72/85
Rotating Direction *2	Tuning clockwise to close and counterclockwise to open valves				
Duty Factor [%ED]	30	30	30	30	30
Valve Closing Time [SEC] *3	EXH 50 Hz	9	14	21	28
	EXH 60 Hz	8	12	17	23
	EXS 50 Hz	—	25	35	49
	EXS 60 Hz	—	21	30	41
Space Heater Volume [W]	100 V AC	15	15	15	15
	200 V AC	15	15	15	15
Position Limit Switch*4	Two switches with voltage and two without voltage supplied				
Switch Contact Voltage	250 V AC 2 A least resistance load				
Insulation Class	JIS Class E, Strength: 1500 V AC 1min. or 1800 V 1sec., Resistance: 100 minimum at 500 V DC				
Overload Protection	Thermal protection				
Service Environment	Indoor / Outdoor (Submergence and direct sunlight must be avoided.)				
Water, Dust — Proof	Equivalent to IP-67				
Ambient Temperature	-10°C to +50°C				
Conduit Port	EXH	One G1/2			
	EXS	Two G1/2			
Mounting Position	From Vertical position to Horizontal position (No downward position)				
Manual Operation	Pull up the manual override handle knob for manual operation, which will activate the built-in interlock switch to cut off power supply. For the restoration of electrical operation, push down the handle knob				
Mechanical Stopper	EXH	Mechanical stoppers are equipped in open and closed position. The stoppers are adjustable by 7 degrees in the both positions			
	EXS	Mechanical stoppers, which can be adjusted in the closed position, are equipped in open and closed position			
Position Indicator	Position indicator, covered by transparent cover, is equipped on the top of the actuator cover				
Mounting Flange	In accordance with ISO5211				

\*1 As the actuator is subjected to approx. tenfold rated current at startup, the contacts of electrical devices connected to the actuator must have enough capacity to handle this large electrical current.  
 \*2 Refer to "Operation manual" for 3 way valves.  
 \*3 Valve closing time is calculated based on an unloaded condition without the valve being mounted. The closing time will be 10% slower, when the valve is mounted.  
 \*4 In case load current is 50 mA or smaller, use limit switches for micro load (minute current).

## Circuit Diagram

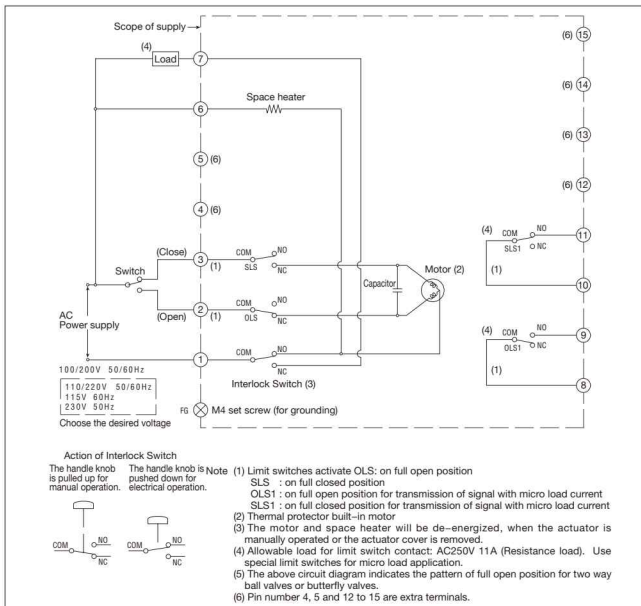

## Product Code

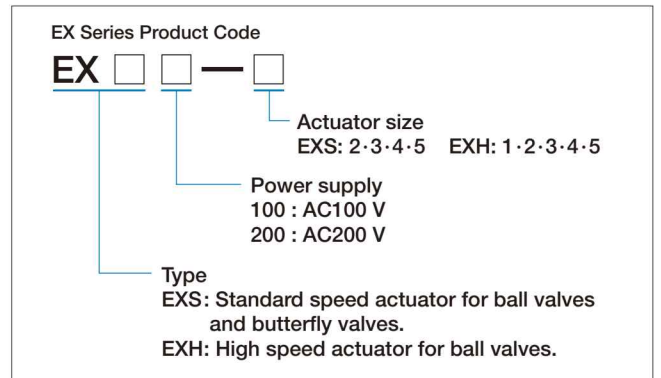

# Actuated Valve

## KITZ C-CS Series Pneumatic Actuators

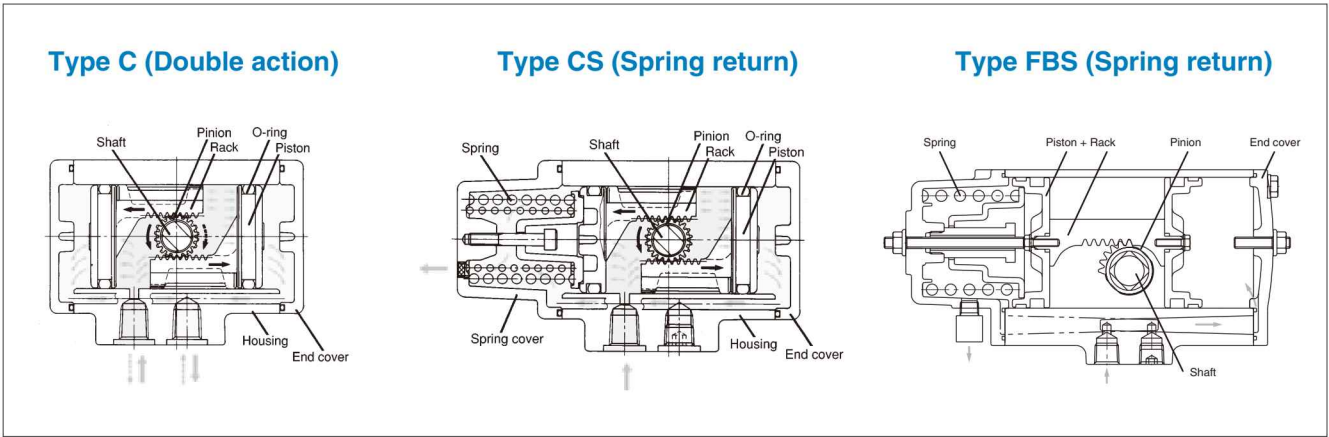

### Actuator design Specifications

Specification	Type	C-1	C-2	CS-1	CS-2	FBS-1
Operating media		Instrumentation air				
Standard operating pressure		0.4 MPa				
Operating pressure range		0.4 to 0.7 MPa				
Output torque* <sup>1</sup>		3.9 N·m	8.5 N·m	1.3 N·m	3.1 N·m	7.6 N·m
Housing shell test pressure		0.97 MPa				
Angle of revolution		90° (+1 to +5°)				90° ± 7°
Cylinder volume (Litter)		0.073	0.160	0.033	0.071	0.15
Operation time		Max. 1 sec.* <sup>4</sup>				
Service temperature range* <sup>2</sup>		-20°C to +60°C -4°F to +140°F				-20°C to +80°C -4°F to +176°F
Ambient condition* <sup>3</sup>		Indoor				

#### Notes:

\*1 At supply pressure 0.4 MPa

\*2 Free from freezing of supply air

\*3 For outdoor service, consult a KITZ engineer

\*4 On a condition of KITZ standard air equipments and no load on

## Design Features of KITZ C-CS / FBS Series Actuators

- Light weight and compact size  
Die-cast aluminum body and double-piston mechanism make the actuator lightweight and compact.
- Simple mechanism  
This actuator consists of a minimum number of parts. This enables the actuator to have a longer service life and lowers the possibility of malfunction.
- Special solenoid valve  
A direct-mount-type special solenoid valve used exclusively for the KITZ C type actuator is available.
- High-efficiency quarter-turn actuator  
The double-piston-type rack and pinion mechanism provides high-efficiency quarter-turn rotation.
- Direct mount type  
The actuator is directly mounted on a valve with only two bolts.

The FBS-type actuator should be chosen for larger-sized valves.

### Standard guide actuator selection

Fig	Size	1/4	3/8	1/2	3/4	1	1 1/4	1 1/2	2
TE		C-1				C-2			
		CS-1	CS-2			(FBS-1)			
TFE		C-1			C-2				
		CS-2	(FBS-1)						
TLE		C-1			C-2				
		CS-2			(FBS-1)				
TNE		C-1				C-2			
		CS-1	CS-2			(FBS-1)			
TGE		C-1	C-2						
		CS-2	(FBS-1)						
TUE		C-1			C-2				
		CS-2							
UTE		C-1				C-2			
		CS-1	CS-2			(FBS-1)			
UTFE		C-1			C-2				
		CS-2	(FBS-1)						
UTGE		C-1			C-2				
		CS-2	(FBS-1)						
5/10UTWE		C-1			C-2				
		CS-2	(FBS-1)						
UTNE		C-1				C-2			
		CS-1	CS-2			(FBS-1)			

For the size ranges not covered by KITZ C Series actuators, more powerful KITZ Type FBS-1 actuators are recommended.

# Features of KITZ B Series Pneumatic Actuators

## Type B (Double-Action)

Internationally patented

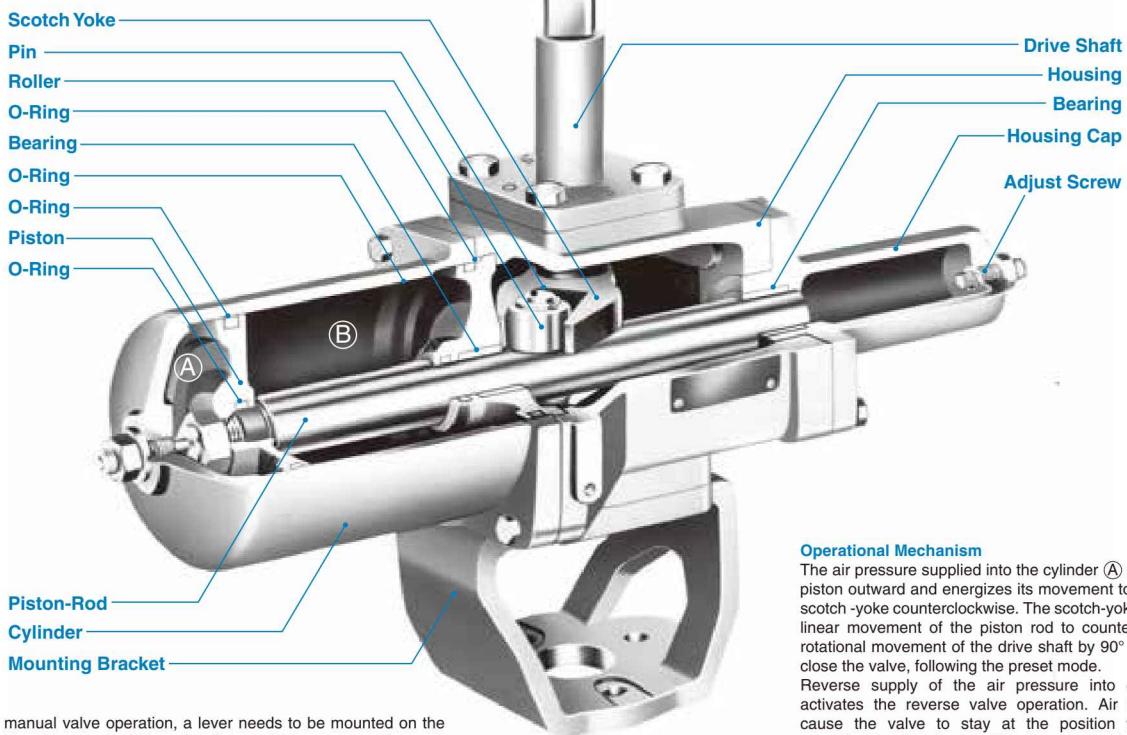

Note: For manual valve operation, a lever needs to be mounted on the top end of the drive shaft of Type B-1 through B-4 actuators. Separate manual operators are available for Type B-5 and B-6 actuators.

### Operational Mechanism

The air pressure supplied into the cylinder (A) pushes the piston outward and energizes its movement to rotate the scotch-yoke counterclockwise. The scotch-yoke converts linear movement of the piston rod to counterclockwise rotational movement of the drive shaft by 90° to open or close the valve, following the preset mode. Reverse supply of the air pressure into cylinder (B) activates the reverse valve operation. Air failure will cause the valve to stay at the position where the operation is disturbed, unlike the valve driven by the Type BS or BWS actuator.

### Smooth operation with minimum friction

Extensive use of fluorocarbon resin to coat the inner parts of the actuator reduces friction to a minimum for smooth operation. This includes the inside of the cylinder, resulting in smooth sliding of the piston and O-rings, as well as the surfaces of the driving shaft, piston rod, and all bearings. As a result, the actuator achieves long-term stable operation.

### Simple, trouble-free construction

The number of parts has been minimized to reduce mechanical problems and simplify periodic checks, maintenance, disassembly, or reassembly.

### Separated turning mechanism and cylinder

Unlike conventional designs, in which the cylinder drive transmission mechanism is incorporated in the cylinder itself, the transmission mechanism of KITZ B Series actuators is designed with a scotch yoke installed separately from the cylinder.

This construction prevents air leakage even when the shaft clearance has increased during service.

### Drive characteristics suited to quarter-turn valves

Unlike conventional cylinder actuators that deploy linear drive characteristics, the use of a scotch yoke mechanism provides a U-shaped curve that maximizes the force obtained at the start and end areas of each stroke. This performance curve is similar to the torque characteristics of ball and butterfly valves in general, making KITZ B Series actuators suitable for such quarter-turn valves (see Page 103).

### Installation of accessories

The actuator housing is provided with an arrangement for mounting limit switches and valve positioners, etc., on its top, and solenoid valves, air filters, and regulators on its side.



## Type BS (Spring-Return) Type BSW (Spring-Return with Manual Operation Device)

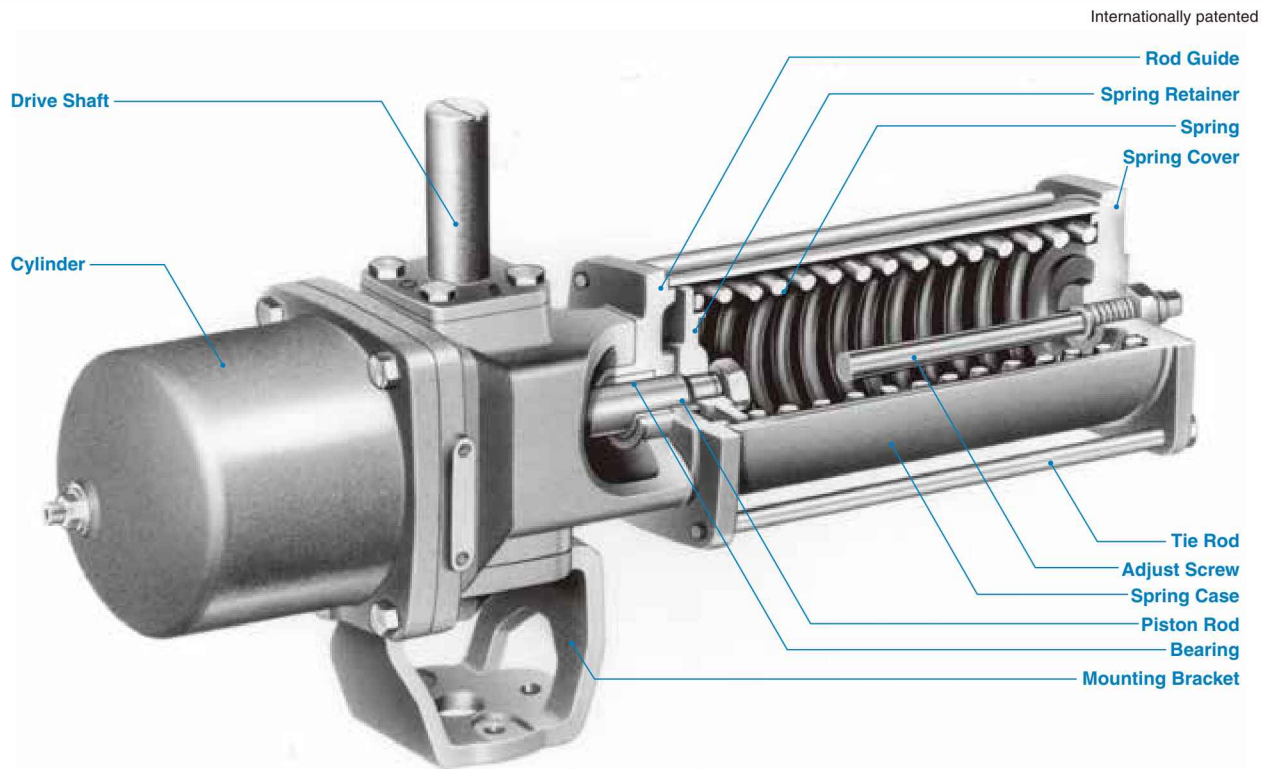

### Operational Mechanism

The air pressure supplied into the cylinder pushes the piston outward and energizes its movement to rotate the scotch-yoke counterclockwise, compressing the spring. The scotch-yoke converts linear movement of the piston rod to counterclockwise rotational movement of the drive shaft by 90°, to open or close the valve, following the preset mode.

At the moment the air is discharged to the atmosphere through the solenoid valve, the spring force pushes the piston to the reverse direction, and the scotch-yoke activates clockwise rotation of the shaft to reversely operate the valve. Air failure will cause the valve to return to the original open or closed position automatically, following the preset mode, unlike the valve driven by the Type B actuator.

The BSW actuator is driven with the same mechanism as the Type BS, but provided with a handwheel for manual operation. Please bear in mind that the handwheel must be factory mounted.

### Type B Actuator Output Torque

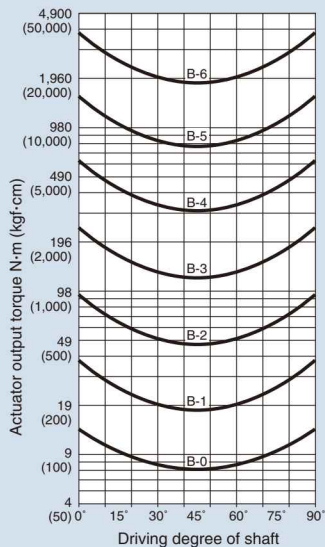

### Type BS/BSW Actuator Output Torque

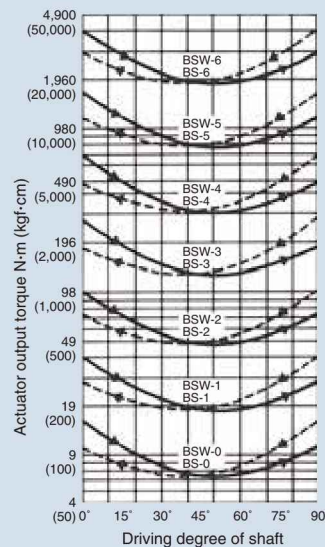

— Output torque when air pressure is supplied.  
- - - Output torque caused by spring force when air pressure is exhausted.

Operating pressure:  
0.4 MPa (4 kgf/cm<sup>2</sup> or 60 psi)

※Please contact KITZ Corporation for B-7, BS-7 and BSW-7.

# KITZ F Series Pneumatic Valve Actuators

Characterized by utmost ease of handling and extended service life with high operational efficiency

**Easy answers to engineering modification requirements**

**Economic advantage**

Use of monobloc casting of the piston-rack assembly results in a 10% to 15% reduction in the housing dimensions (compared to KITZ D Series actuators) and saves air consumption for valve actuation.

**Extended service life with monobloc casting of two pistons and a gear rack**

Threads of a gear rack are positioned in the center of the actuator housing, and two pistons are cast in combination with the gear rack as a one-piece unit. This helps to keep the piston position in parallel during actuator travel.

**Light and compact housing**

Employment of die-cast aluminum for housings and piston-rack assemblies has reduced the actuator weight by 20% to 40% (compared to KITZ D Series actuators) for improved torque to weight ratio.

**Conformity to international standards**

NAMUR VDI/VDE 3845 designs are for tubeless mounting of a solenoid valve and switchbox on the actuator housing as well as conforming to ISO 5211 requirements for valve mounting flanges. The stem top design also conforms to NAMUR dimensions.

**Actuators can be directly mounted to KITZ DJ, XJ Series Butterfly Valves**

Optional adaptors (connectors) to the valves at the bottom of the actuators can be provided for various mounting requirements.

## Operating Mechanism

**Double action (Type FA)**

- (1) Air pressure supplied to chamber **A** through port ① pushes the gear rack with two pistons outward and discharges the air residue through port ②.
- (2) The gear rack rotates the pinion gear and the shaft counterclockwise to drive the valve.
- (3) Reverse supply of the air pressure activates reverse valve operation.

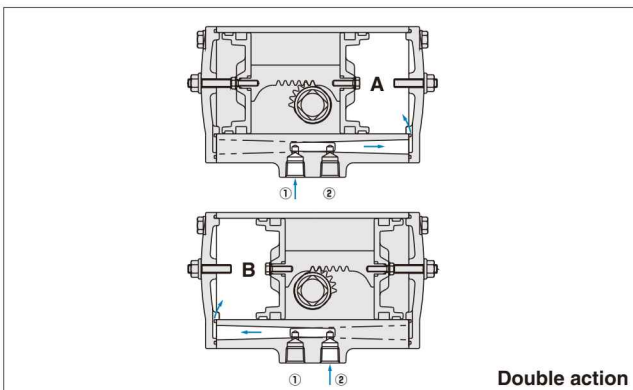

**Spring return (Type FAS)**

- (1) Air pressure supplied to chamber **A** through port ① pushes the gear rack with two pistons outward, compresses the springs, and discharges the air residue through port ②.
- (2) The gear rack rotates the pinion gear and the shaft counterclockwise to drive the valve.
- (3) At the instant when the air in chamber **A** is discharged through the solenoid valve, the spring force pushes the pistons to the reverse direction and the gear rack activates clockwise rotation of the shaft to reversely operate the valve.

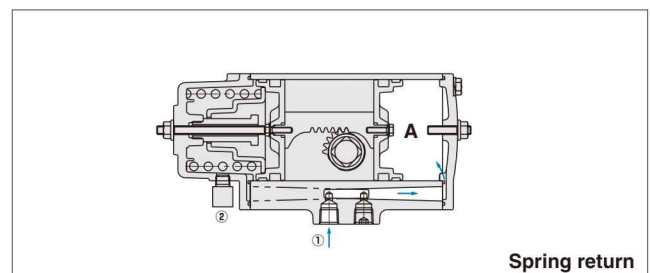

## Design Features

### Double Action Type FA

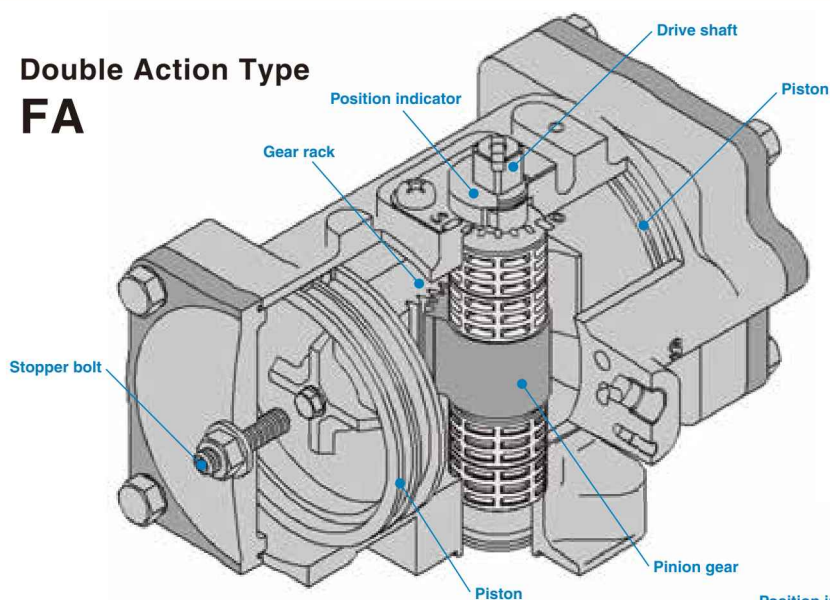

### Spring Return Type FAS

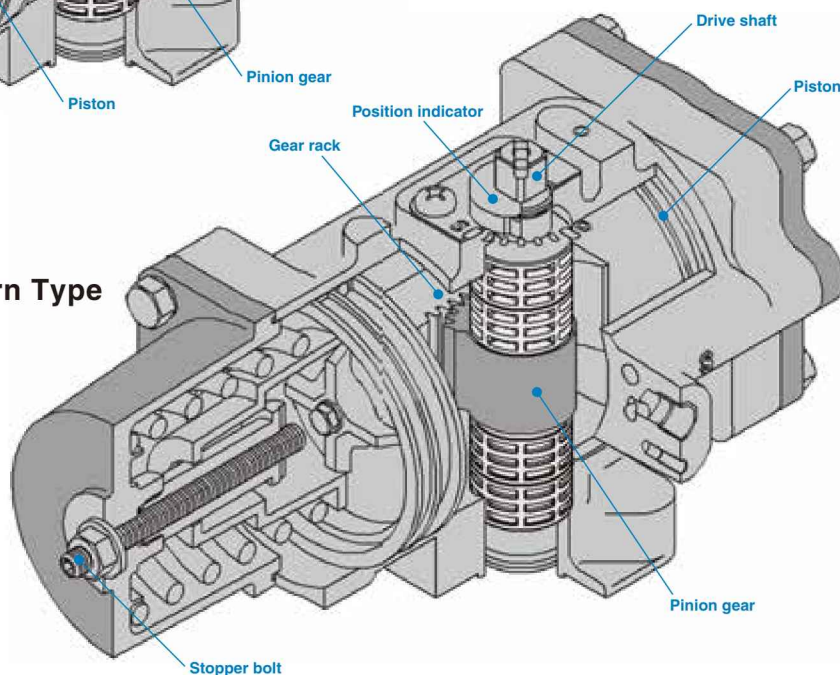

## Specification

Operating medium	Compressed instrumentation air or nitrogen gas
Operating pressure	Standard operating pressure 0.4 MPa
Operating pressure range	0.3 MPa to 0.7 MPa*
Cylinder test pressure	0.97 MPa
Shaft rotating angle	90°±7°
Service temperature	-20°C to +80°C (Supply air should not be frozen.)
Opening degree indication	Indicator has 15 degree graduation
Valve mounting flange	ISO 5211
Accessory mounting connection	NAMUR VDI/VDE 3845
Coating	Baked Polyester Resin Coating

\* Be consulted by KITZ for non-standard operating pressure.

## Product Coding

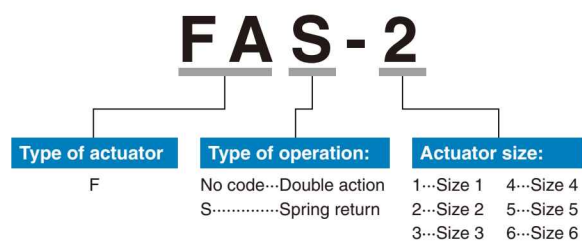



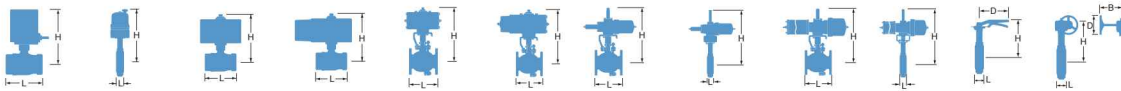



TYPE	FLOATING BALL			FLOATING BALL			FLOATING BALL			3WAY FLOATING BALL / 3WAY TRUNNION BALL			FLOATING BALL				
Actuators Valves																	
FIG	EA100/200-TE			EA100/200-TFE			EA100/200-TGE			EA100/200-TNE			EA100/200-UTE				
PRESSURE	10K			10K			10K			10K			10K				
END CONNECTION	BS21 (JIS B0203)			BS21 (JIS B0203)			BS21 (JIS B0203)			BS21 (JIS B0203)			BS21 (JIS B0203)				
DIMENSIONS	inch	mm	L	H	D	L	H	D	L	H	D	L	H	D	L	H	D
	1/4	8	—	—	—	—	—	—	—	—	—	46	101.5	—	44	102	—
	3/8	10	46	104	—	—	—	—	46	130	—	46	101.5	—	44	102	—
	1/2	15	65	109.5	—	63	113.5	—	65	135.5	—	67	109.5	—	56.5	102	—
	3/4	20	68	113.5	—	73	117.5	—	68	139.5	—	68	114	—	59	105	—
	1	25	79	117.5	—	85	128.5	—	79	143.5	—	79	118	—	71	108	—
	1 1/4	32	86	128.5	—	98	142.2	—	—	—	—	89	129.5	—	78	132.5	—
	1 1/2	40	96	142.5	—	108	148.5	—	—	—	—	100	142.5	—	83	135.5	—
2	50	109	148.5	—	—	—	—	—	—	—	115	148.5	—	100	141.5	—	
BODY	Cast Bronze			Forged Brass / Cast Bronze			Cast Bronze			Cast Bronze			Stainless Steel				
CAP	Forged Brass			Forged Brass			Forged Brass			Forged Brass			—				
STEM	High Tension Brass			High Tension Brass			High Tension Brass			High Tension Brass			Stainless Steel				
BALL	Special Brass			Special Brass			Special Brass			Special Brass			Stainless Steel				
SEAT	PTFE			PTFE			REINFORCED PTFE			PTFE			PTFE				
	Standard Port			Full Port			Standard Port			Standard Port			Reduced Port				

TYPE	FLOATING BALL			FLOATING BALL			3WAY FLOATING BALL			FLOATING BALL / TRUNNION BALL			3WAY FLOATING BALL / 3WAY TRUNNION BALL				
Actuators Valves																	
FIG	EA100/200-UTFE			EA100/200-UTGE			EA100/200-UTNE			ED12/24-TE			ED12/24-TNE				
PRESSURE	10K			10K			10K			10K			10K				
END CONNECTION	BS21 (JIS B0203)			BS21 (JIS B0203)			BS21 (JIS B0203)			BS21 (JIS B0203)			BS21 (JIS B0203)				
DIMENSIONS	inch	mm	L	H	D	L	H	D	L	H	D	L	H	D	L	H	D
	1/4	8	—	—	—	44	128	—	44	101.5	—	—	—	—	46	109.5	—
	3/8	10	—	—	—	44	128	—	44	101.5	—	46	112	—	46	109.5	—
	1/2	15	62	113.5	—	56.5	128	—	58	106.5	—	65	117.5	—	67	117.5	—
	3/4	20	73	117.5	—	59	131	—	61.5	110.5	—	68	121.5	—	68	122	—
	1	25	85	128.5	—	71	134	—	74	114	—	79	120.5	—	79	121	—
	1 1/4	32	98	143	—	—	—	—	82.5	132.5	—	86	124.5	—	89	125.5	—
	1 1/2	40	108	149	—	—	—	—	90.5	135.5	—	96	138.5	—	100	138.5	—
2	50	—	—	—	—	—	—	109.5	141.5	—	109	144.5	—	115	144.5	—	
BODY	Stainless Steel			Stainless Steel			Stainless Steel			Cast Bronze			Cast Bronze				
CAP	Stainless Steel			—			—			Forged Brass			Forged Brass				
STEM	Stainless Steel			Stainless Steel			Stainless Steel			High Tension Brass			High Tension Brass				
BALL	Stainless Steel			Stainless Steel			Stainless Steel			Special Brass			Special Brass				
SEAT	PTFE			REINFORCED PTFE			C/F PTFE			PTFE			PTFE				
	Full Port			Reduced Port			Reduced Port			Standard Port			Standard Port				

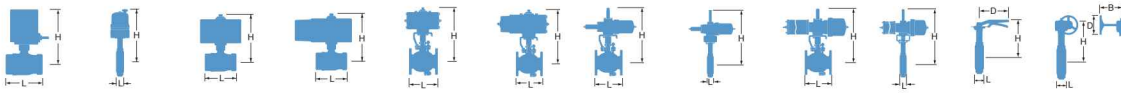

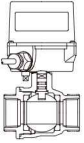
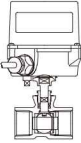

TYPE	FLOATING BALL					FLOATING BALL / TRUNNION BALL				FLOATING BALL		
Actuators Valves												
FIG	ED12/24-UTE					ED12/24-UTFE				ED12/24-UTGE		
PRESSURE	10K					10K				10K		
END CONNECTION	BS21 (JIS B0203)					BS21 (JIS B0203)				BS21 (JIS B0203)		
DIMENSIONS	inch	mm	L	H	D	L	H	D	L	H	D	
	1/4	8	44	110	—	—	—	—	44	123.5	—	
	3/8	10	44	110	—	—	—	—	44	123.5	—	
	1/2	15	56.5	110	—	62	121.5	—	56.5	124	—	
	3/4	20	59	113	—	73	121.5	—	59	126.5	—	
	1	25	71	116	—	85	125.5	—	71	129.4	—	
	1 1/4	32	78	128.5	—	98	140.5	—	—	—	—	
	1 1/2	40	83	131.5	—	108	146.5	—	—	—	—	
2	50	100	137.5	—	—	—	—	—	—	—		
BODY	Stainless Steel					Stainless Steel				Stainless Steel		
CAP	—					Stainless Steel				—		
STEM	Stainless Steel					Stainless Steel				Stainless Steel		
BALL	Stainless Steel					Stainless Steel				Stainless Steel		
SEAT	PTFE					PTFE				REINFORCED PTFE		
	Reduced Port					Full Port				Reduced Port		

Brass & Bronze

Cast Iron

Ductile Iron

Stainless Steel

Carbon Steel

Butterfly Valve

Ball Valve

Ball Valve Seat

Actuated Valve

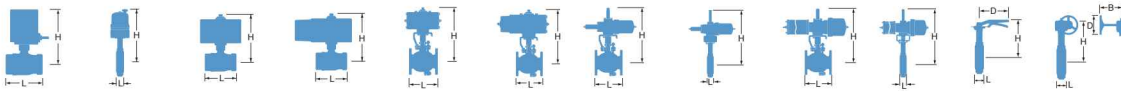

TYPE		BUTTERFLY			BUTTERFLY			BUTTERFLY			
Actuators Valves											
FIG		EXS100/200-10DJ			EXS100/200-10DJE			EXS100/200-10XJME			
PRESSURE		10K			10K			10K			
END CONNECTION		Wafer Type (JIS 5K,10K)			Wafer Type (JIS 5K,10K)			Wafer Type (JIS 5K,10K)			
DIMENSIONS	inch	mm	L	H	D	L	H	D	L	H	D
	1 1/2	40	—	—	—	—	—	—	33	309	—
	2	50	43	328	—	43	328	—	43	313	—
	2 1/2	65	46	336	—	46	336	—	46	322	—
	3	80	46	354	—	46	354	—	46	330	—
	4	100	52	364	—	52	364	—	52	341	—
	5	125	56	417.5	—	56	417.5	—	56	401	—
	6	150	56	429.5	—	56	429.5	—	56	413.5	—
	8	200	60	454.5	—	60	454.5	—	60	440	—
	10	250	68	580	—	68	580	—	68	604	—
	12	300	78	605	—	78	605	—	78	629	—
	14	350	78	717	—	78	717	—	—	—	—
	16	400	102	772	—	102	772	—	—	—	—
BODY		Ductile Iron			Ductile Iron			Aluminum Die-Cast			
STEM		Stainless Steel			Stainless Steel			Stainless Steel			
BALL		Ductile Iron+ENP			Ductile Iron+ENP			Stainless Steel			
SEAT		NBR			EPDM			EPDM			
		Ductile iron (Ni-plated) disc			Ductile iron (Ni-plated) disc						

Bronze & Brass  
 Cast Iron  
 Ductile Iron  
 Stainless Steel  
 Carbon Steel  
 Butterfly Valve  
 Ball Valve  
 Ball Valve Seat  
 Actuated Valve

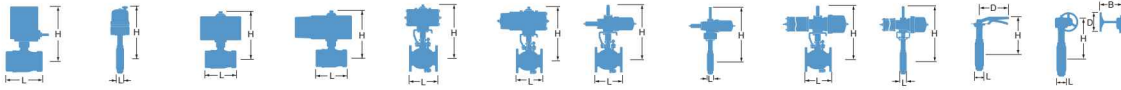

TYPE	FLOATING BALL / TRUNNION BALL			FLOATING BALL / TRUNNION BALL			FLOATING BALL			FLOATING BALL / TRUNNION BALL			3WAY FLOATING BALL / 3WAY TRUNNION BALL				
Actuators Valves																	
FIG	C-TE			C-TFE			C-TGE			C-TLE			C-TNE				
PRESSURE	10K			10K			10K			10K			10K				
END CONNECTION	BS21 (JIS B0203)			BS21 (JIS B0203)			BS21 (JIS B0203)			BS21 (JIS B0203)			BS21 (JIS B0203)				
DIMENSIONS	inch	mm	L	H	D	L	H	D	L	H	D	L	H	D	L	H	D
	1/4	8	—	—	—	—	—	—	—	—	—	—	—	—	46	85.5	—
	3/8	10	46	87.5	—	—	—	—	46	107.5	—	—	—	—	46	85.5	—
	1/2	15	65	93.5	—	63	97.5	—	65	132.5	—	56	115.5	—	67	93.5	—
	3/4	20	68	97.5	—	73	101.5	—	68	136.5	—	65	120.5	—	68	97.5	—
	1	25	79	101.5	—	85	124.5	—	79	140.5	—	78	123.5	—	79	101.5	—
	1 1/4	32	86	124.5	—	98	138.5	—	—	—	—	86	158.5	—	89	125.5	—
	1 1/2	40	96	137.5	—	108	144.5	—	—	—	—	96	161.5	—	100	138.5	—
2	50	109	144.5	—	—	—	—	—	—	—	109	168.5	—	115	144.5	—	
BODY	Cast Bronze			Forged Brass / Cast Bronze			Cast Bronze			Cast Bronze			Cast Bronze				
CAP	Forged Brass			Forged Brass			Forged Brass			Cast Bronze			Forged Brass				
STEM	High Tension Brass			High Tension Brass			High Tension Brass			High Tension Brass			High Tension Brass				
BALL	Special Brass			Special Brass			Special Brass			Special Brass			Special Brass				
SEAT	PTFE			PTFE			REINFORCED PTFE			PTFE			PTFE				
	Standard Port			Full Port			Standard Port			Standard Port			Standard Port				

TYPE	FLOATING BALL			FLOATING BALL			FLOATING BALL			3WAY FLOATING BALL			FLOATING BALL				
Actuators Valves																	
FIG	C-TUE			C-UTE			C-UTGE			C-UTNE			CS-TE				
PRESSURE	10K			10K			10K			10K			10K				
END CONNECTION	BS21 (JIS B0203)			BS21 (JIS B0203)			BS21 (JIS B0203)			BS21 (JIS B0203)			BS21 (JIS B0203)				
DIMENSIONS	inch	mm	L	H	D	L	H	D	L	H	D	L	H	D	L	H	D
	1/4	8	—	—	—	44	85.5	—	44	105.5	—	44	85	—	—	—	—
	3/8	10	—	—	—	44	85.5	—	44	105.5	—	44	85	—	46	87.5	—
	1/2	15	78.5	85.5	—	56.5	85.5	—	56.5	124.5	—	58	90	—	65	112.5	—
	3/4	20	81	88.5	—	59	88.5	—	59	127.5	—	61.5	94	—	68	116.5	—
	1	25	—	—	—	71	91.5	—	71	130.5	—	74	97.5	—	79	120.5	—
	1 1/4	32	—	—	—	78	128.5	—	—	—	—	82.5	128	—	—	—	—
	1 1/2	40	—	—	—	83	131.5	—	—	—	—	90.5	131	—	—	—	—
2	50	—	—	—	100	137.5	—	—	—	—	109.5	137	—	—	—	—	
BODY	Cast Bronze			Stainless Steel			Stainless Steel			Stainless Steel			Cast Bronze				
CAP	—			—			—			—			Forged Brass				
STEM	High Tension Brass			Stainless Steel			Stainless Steel			Stainless Steel			High Tension Brass				
BALL	Special Brass			Stainless Steel			Stainless Steel			Stainless Steel			Special Brass				
SEAT	PTFE			PTFE			REINFORCED PTFE			C/F PTFE			PTFE				
	Reduced Port			Reduced Port			Reduced Port			Reduced Port			Standard Port				

Bronze &amp; Brass

Cast Iron

Ductile Iron

Stainless Steel

Carbon Steel

Butterfly Valve

Ball Valve

Ball Valve Seal

Actuated Valve

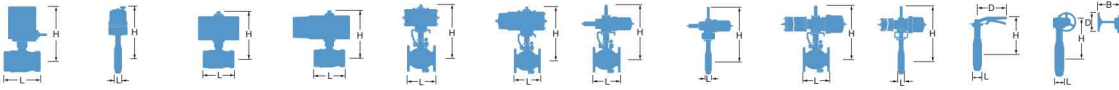

TYPE	FLOATING BALL				3WAY FLOATING BALL			FLOATING BALL			FLOATING BALL			FLOATING BALL			
Actuators Valves																	
FIG	CS-TLE				CS-TNE			CS-TUE			CS-UTE			CS-UTGE			
PRESSURE	10K				10K			10K			10K			10K			
END CONNECTION	BS21 (JIS B0203)				BS21 (JIS B0203)			BS21 (JIS B0203)			BS21 (JIS B0203)			BS21 (JIS B0203)			
DIMENSIONS	inch	mm	L	H	D	L	H	D	L	H	D	L	H	D	L	H	D
	1/4	8	-	-	-	46	85.5	-	-	-	-	44	85.5	-	44	124.5	-
	3/8	10	-	-	-	46	85.5	-	-	-	-	44	85.5	-	44	124.5	-
	1/2	15	56	134.5	-	67	112.5	-	78.5	104.5	-	56.5	104.5	-	-	-	-
	3/4	20	65	139.5	-	68	116.5	-	81	107.5	-	59	107.5	-	-	-	-
	1	25	78	142.5	-	79	120.5	-	-	-	-	71	110.5	-	-	-	-
BODY	Cast Bronze				Cast Bronze			Cast Bronze			Stainless Steel			Stainless Steel			
CAP	Cast Bronze				Forged Brass			-			-			-			
STEM	High Tension Brass				High Tension Brass			High Tension Brass			Stainless Steel			Stainless Steel			
BALL	Special Brass				Special Brass			Special Brass			Stainless Steel			Stainless Steel			
SEAT	PTFE				PTFE			PTFE			PTFE			Reinforced PTFE			
	Standard Port				Standard Port			Reduced Port			Reduced Port			Reduced Port			

TYPE	3WAY FLOATING BALL				FLOATING BALL			FLOATING BALL			3WAY FLOATING BALL			FLOATING BALL			
Actuators Valves																	
FIG	CS-UTNE				FA-10FCT			FA-10FCTB			FA-10FCTB2L			FA-10SCTDZ			
PRESSURE	10K				10K			10K			10K			10K			
END CONNECTION	BS21 (JIS B0203)				BS21 (JIS B0203)			JIS B2239			JIS B2239			JIS B2220			
DIMENSIONS	inch	mm	L	H	D	L	H	D	L	H	D	L	H	D	L	H	D
	1/4	8	44	85	-	-	-	-	-	-	-	-	-	-	-	-	-
	3/8	10	44	85	-	72	216	-	-	-	-	-	-	-	-	-	-
	1/2	15	58	109	-	80	225	-	110	225	-	-	-	-	108	215	-
	3/4	20	61.5	113	-	85	228	-	120	228	-	-	-	-	117	218	-
	1	25	74	116.5	-	95	235	-	130	235	-	-	-	-	127	240	-
	1 1/4	32	-	-	-	120	239	-	140	239	-	-	-	-	-	-	-
	1 1/2	40	-	-	-	120	297	-	165	297	-	210	297	-	165	297	-
	2	50	-	-	-	140	304	-	180	304	-	220	306	-	178	306	-
	2 1/2	65	-	-	-	160	345	-	190	345	-	250	347	-	190	363	-
	3	80	-	-	-	182	413	-	200	413	-	260	413	-	203	419	-
	4	100	-	-	-	-	-	-	230	436	-	330	440	-	229	447	-
	5	125	-	-	-	-	-	-	300	520	-	-	-	-	356	519	-
	6	150	-	-	-	-	-	-	340	545	-	-	-	-	394	552	-
	8	200	-	-	-	-	-	-	450	628	-	-	-	-	457	656	-
BODY	Stainless Steel				Cast Iron			Cast Iron			Cast Iron			Cast Steel			
CAP	-				Cast Iron			Cast Iron			Cast Iron			Cast Steel			
STEM	Stainless Steel				Stainless Steel			Stainless Steel			Stainless Steel			Stainless Steel			
BALL	Stainless Steel				Stainless Steel			Stainless Steel			Stainless Steel			Stainless Steel			
SEAT	C/F PTFE				PTFE			PTFE			PTFE			HYPATITE® PTFE			
	Reduced Port				Full Port			Full Port			Full Port			Full Port			



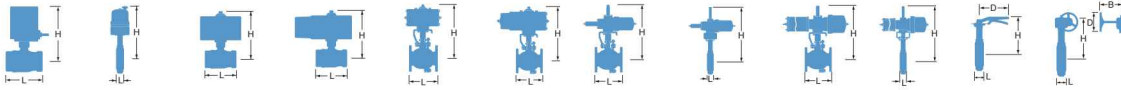

TYPE	FLOATING BALL			3WAY FLOATING BALL			3WAY FLOATING BALL			FLOATING BALL			FLOATING BALL				
Actuators Valves																	
FIG	FA-10UT			FA-10UTB2L			FA-10UTB4LA			FA-10UTBLN			FA-10UTDZ				
PRESSURE	10K			10K			10K			10K			10K				
END CONNECTION	BS21 (JIS B2023)			JIS B2220			JIS B2220			JIS B2220			JIS B2220				
DIMENSIONS	inch	mm	L	H	D	L	H	D	L	H	D	L	H	D	L	H	D
	3/8	10	62	216	—	—	—	—	—	—	—	—	—	—	—	—	—
	1/2	15	65	225	—	—	—	—	120	237	—	140	228	—	108	215	—
	3/4	20	80	228	—	—	—	—	140	263	—	152	229	—	117	218	—
	1	25	90	235	—	165	235	—	160	267	—	165	240	—	127	240	—
	1 1/4	32	110	239	—	—	—	—	—	—	—	—	—	—	140	244	—
	1 1/2	40	120	297	—	210	297	—	180	335	—	191	301	—	165	297	—
	2	50	140	304	—	220	304	—	200	403	—	216	307	—	178	306	—
	2 1/2	65	160	345	—	250	347	—	240	422	—	240	347	—	190	363	—
	3	80	182	413	—	260	413	—	260	498	—	250	416	—	203	419	—
4	100	—	—	—	330	440	—	330	549	—	280	442	—	229	447	—	
5	125	—	—	—	—	—	—	—	—	—	—	—	—	356	519	—	
6	150	—	—	—	—	—	—	—	—	—	—	—	—	394	552	—	
8	200	—	—	—	—	—	—	—	—	—	—	—	—	457	656	—	
BODY	Stainless Steel			Stainless Steel			Stainless Steel			Stainless Steel			Stainless Steel				
CAP	Stainless Steel			Stainless Steel			Stainless Steel			Stainless Steel			Stainless Steel				
STEM	Stainless Steel			Stainless Steel			Stainless Steel			Stainless Steel			Stainless Steel				
BALL	Stainless Steel			Stainless Steel			Stainless Steel			Stainless Steel			Stainless Steel				
SEAT	PTFE			HYPATITE® PTFE			HYPATITE® PTFE			HYPATITE® PTFE			HYPATITE® PTFE				
	Full Port			Full Port			Full Port			Full Port			Full Port				

TYPE	FLOATING BALL			FLOATING BALL			FLOATING BALL			FLOATING BALL			FLOATING BALL				
Actuators Valves																	
FIG	FA-150SCTDZ			FA-150UTDZ			FA-20SCTDZ			FA-20UTDZ			FA-300SCTDZ				
PRESSURE	Class 150			Class 150			20K			20K			Class 300				
END CONNECTION	ASME B16.5			ASME B16.5			JIS B2220			JIS B2220			ASME B16.5				
DIMENSIONS	inch	mm	L	H	D	L	H	D	L	H	D	L	H	D	L	H	D
	1/2	15	108	215	—	108	215	—	140	215	—	140	215	—	140	215	—
	3/4	20	117	218	—	117	218	—	152	218	—	152	218	—	152	218	—
	1	25	127	240	—	127	240	—	165	240	—	165	240	—	165	240	—
	1 1/4	32	—	—	—	140	244	—	—	—	—	178	244	—	—	—	—
	1 1/2	40	165	297	—	165	297	—	190	297	—	190	297	—	190	297	—
	2	50	178	306	—	178	306	—	216	306	—	216	306	—	216	306	—
	2 1/2	65	190	363	—	190	363	—	241	363	—	241	363	—	241	363	—
	3	80	203	419	—	203	419	—	283	419	—	283	419	—	283	419	—
	4	100	229	447	—	229	447	—	305	447	—	305	447	—	305	447	—
5	125	356	519	—	356	519	—	381	519	—	381	519	—	—	—	—	
6	150	394	552	—	394	552	—	403	552	—	403	552	—	403	552	—	
8	200	457	656	—	457	656	—	502	656	—	502	656	—	502	656	—	
BODY	Cast Steel			Stainless Steel			Cast Steel			Stainless Steel			Cast Steel				
CAP	Cast Steel			Stainless Steel			Cast Steel			Stainless Steel			Cast Steel				
STEM	Stainless Steel			Stainless Steel			Stainless Steel			Stainless Steel			Stainless Steel				
BALL	Stainless Steel			Stainless Steel			Stainless Steel			Stainless Steel			Stainless Steel				
SEAT	HYPATITE® PTFE			HYPATITE® PTFE			HYPATITE® PTFE			HYPATITE® PTFE			HYPATITE® PTFE				
	Full Port			Full Port			Full Port			Full Port			Full Port				

Bronze & Brass

Cast Iron

Ductile Iron

Stainless Steel

Carbon Steel

Butterfly Valve

Ball Valve

Ball Valve Seat

Actuated Valve

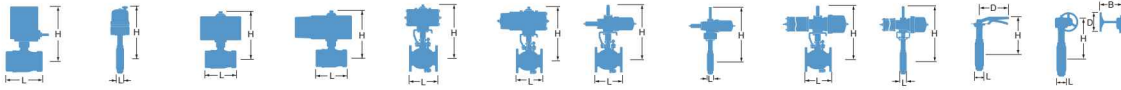

TYPE	FLOATING BALL					FLOATING BALL			BUTTERFLY			BUTTERFLY			BUTTERFLY		
Actuators Valves																	
FIG	FA-300UTDZ					FA-300UTDZM			FA-10XJME			FA-10DJ			FA-10DJE		
PRESSURE	Class 300					Class 300			10K			10K			10K		
END CONNECTION	ASME B16.5					ASME B16.5			Wafer Type (JIS 5K,10K)			Wafer Type (JIS 5K,10K)			Wafer Type (JIS 5K,10K)		
DIMENSIONS	inch	mm	L	H	D	L	H	D	L	H	D	L	H	D	L	H	D
	1/2	15	140	215	—	140	215	—	—	—	—	—	—	—	—	—	—
	3/4	20	152	218	—	152	218	—	—	—	—	—	—	—	—	—	—
	1	25	165	240	—	165	240	—	—	—	—	—	—	—	—	—	—
	1 1/2	40	190	297	—	190	297	—	33	251	—	—	—	—	—	—	—
	2	50	216	306	—	216	306	—	43	255	—	43	270	—	43	270	—
	2 1/2	65	241	363	—	241	363	—	46	287	—	46	278	—	46	278	—
	3	80	283	419	—	283	419	—	46	295	—	46	319	—	46	319	—
	4	100	305	447	—	305	447	—	52	306	—	52	329	—	52	329	—
	5	125	—	—	—	—	—	—	56	357	—	56	373	—	56	373	—
	6	150	403	552	—	403	552	—	56	369	—	56	385	—	56	385	—
	8	200	502	656	—	502	656	—	60	435	—	60	449	—	60	449	—
	10	250	—	—	—	—	—	—	68	573	—	68	549	—	68	549	—
	12	300	—	—	—	—	—	—	78	627	—	78	603	—	78	603	—
BODY	Stainless Steel					Stainless Steel			Aluminum Die-Cast			Ductile Iron			Ductile Iron		
CAP	Stainless Steel					Stainless Steel			—			—			—		
STEM	Stainless Steel					Stainless Steel			Stainless Steel			Stainless Steel			Stainless Steel		
BALL	Stainless Steel					Stainless Steel			Stainless Steel			Ductile Iron+ENP			Ductile Iron+ENP		
SEAT	HYPATITE® PTFE					HYPATITE® PTFE			EPDM			NBR			EPDM		
	Full Port					Full Port						Ductile iron (Ni-plated) disc			Ductile iron (Ni-plated) disc		

TYPE	FLOATING BALL					FLOATING BALL			3WAY FLOATING BALL			FLOATING BALL			FLOATING BALL		
Actuators Valves																	
FIG	FAS-10FCT					FAS-10FCTB			FAS-10FCTB2L			FAS-10SCTDZ			FAS-10UT		
PRESSURE	10K					10K			10K			10K			10K		
END CONNECTION	BS21 (JIS B0203)					JIS B2239			JIS B2239			JIS B2220			BS21 (JIS B0203)		
DIMENSIONS	inch	mm	L	H	D	L	H	D	L	H	D	L	H	D	L	H	D
	3/8	10	72	216	—	—	—	—	—	—	—	—	—	—	62	216	—
	1/2	15	80	225	—	110	225	—	—	—	—	108	215	—	65	225	—
	3/4	20	85	228	—	120	228	—	—	—	—	117	241	—	80	228	—
	1	25	95	258	—	130	258	—	—	—	—	127	276	—	90	258	—
	1 1/4	32	120	262	—	140	262	—	—	—	—	—	—	—	110	262	—
	1 1/2	40	120	313	—	165	313	—	210	313	—	165	313	—	120	313	—
	2	50	140	343	—	180	343	—	220	345	—	178	355	—	140	343	—
	2 1/2	65	160	404	—	190	404	—	250	406	—	190	409	—	160	404	—
	3	80	182	468	—	200	468	—	260	468	—	203	475	—	182	468	—
	4	100	—	—	—	230	500	—	330	504	—	229	503	—	—	—	—
	5	125	—	—	—	300	549	—	—	—	—	356	548	—	—	—	—
	6	150	—	—	—	340	574	—	—	—	—	394	581	—	—	—	—
BODY	Cast Iron					Cast Iron			Cast Iron			Cast Steel			Stainless Steel		
CAP	Cast Iron					Cast Iron			Cast Iron			Cast Steel			Stainless Steel		
STEM	Stainless Steel					Stainless Steel			Stainless Steel			Stainless Steel			Stainless Steel		
BALL	Stainless Steel					Stainless Steel			Stainless Steel			Stainless Steel			Stainless Steel		
SEAT	PTFE					PTFE			PTFE			HYPATITE® PTFE			PTFE		
	Full Port					Full Port			Full Port			Full Port			Full Port		

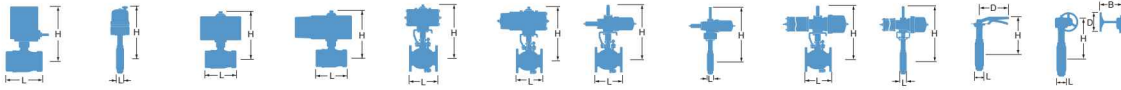

TYPE	3WAY FLOATING BALL			3WAY FLOATING BALL			FLOATING BALL			FLOATING BALL			FLOATING BALL				
Actuators Valves																	
FIG	FAS-10UTB2L			FAS-10UTB4LA			FAS-10UTBLN			FAS-10UTDZ			FAS-150SCTDZ				
PRESSURE	10K			10K			10K			10K			Class 150				
END CONNECTION	JIS B2220			JIS B2220			JIS B2220			JIS B2220			ASME B16.5				
DIMENSIONS	inch	mm	L	H	D	L	H	D	L	H	D	L	H	D	L	H	D
	1/2	15	—	—	—	120	260	—	140	228	—	108	215	—	108	215	—
	3/4	20	—	—	—	140	279	—	152	229	—	117	241	—	117	241	—
	1	25	165	258	—	160	283	—	165	263	—	127	276	—	127	276	—
	1 1/4	32	—	—	—	—	—	—	—	—	—	140	280	—	—	—	—
	1 1/2	40	210	313	—	180	394	—	191	317	—	165	313	—	165	313	—
	2	50	220	345	—	200	458	—	216	346	—	178	355	—	178	355	—
	2 1/2	65	250	406	—	240	515	—	240	406	—	190	409	—	190	409	—
	3	80	260	468	—	260	527	—	250	471	—	203	475	—	203	475	—
4	100	330	504	—	—	—	—	280	506	—	229	503	—	229	503	—	
5	125	—	—	—	—	—	—	—	—	—	356	548	—	356	548	—	
6	150	—	—	—	—	—	—	—	—	—	394	581	—	394	581	—	
BODY	Stainless Steel			Stainless Steel			Stainless Steel			Stainless Steel			Cast Steel				
CAP	Stainless Steel			Stainless Steel			Stainless Steel			Stainless Steel			Cast Steel				
STEM	Stainless Steel			Stainless Steel			Stainless Steel			Stainless Steel			Stainless Steel				
BALL	Stainless Steel			Stainless Steel			Stainless Steel			Stainless Steel			Stainless Steel				
SEAT	HYPATITE® PTFE			HYPATITE® PTFE			HYPATITE® PTFE			HYPATITE® PTFE			HYPATITE® PTFE				
	Full Port			Full Port			Full Port			Full Port			Full Port				

TYPE	FLOATING BALL			FLOATING BALL			FLOATING BALL			FLOATING BALL			FLOATING BALL				
Actuators Valves																	
FIG	FAS-150UTDZ			FAS-150UTDZM			FAS-20SCTDZ			FAS-20UTDZ			FAS-300SCTDZ				
PRESSURE	Class 150			Class 150			20K			20K			Class 300				
END CONNECTION	ASME B16.5			ASME B16.5			JIS B2220			JIS B2220			ASME B16.5				
DIMENSIONS	inch	mm	L	H	D	L	H	D	L	H	D	L	H	D	L	H	D
	1/2	15	108	215	—	108	215	—	140	215	—	140	215	—	140	215	—
	3/4	20	117	241	—	117	241	—	152	241	—	152	241	—	152	241	—
	1	25	127	276	—	127	276	—	165	276	—	165	276	—	165	276	—
	1 1/4	32	140	280	—	140	280	—	—	—	—	178	280	—	—	—	—
	1 1/2	40	165	313	—	165	313	—	190	313	—	190	313	—	190	313	—
	2	50	178	355	—	178	355	—	216	355	—	216	355	—	216	355	—
	2 1/2	65	190	409	—	190	409	—	241	409	—	241	409	—	241	409	—
	3	80	203	475	—	203	475	—	283	475	—	283	475	—	283	475	—
4	100	229	503	—	229	503	—	305	503	—	305	503	—	305	503	—	
5	125	356	548	—	356	548	—	381	548	—	381	548	—	—	—	—	
6	150	394	581	—	394	581	—	403	581	—	403	581	—	403	581	—	
BODY	Stainless Steel			Stainless Steel			Cast Steel			Cast Steel			Cast Steel				
CAP	Stainless Steel			Stainless Steel			Cast Steel			Cast Steel			Cast Steel				
STEM	Stainless Steel			Stainless Steel			Stainless Steel			Stainless Steel			Stainless Steel				
BALL	Stainless Steel			Stainless Steel			Stainless Steel			Stainless Steel			Stainless Steel				
SEAT	HYPATITE® PTFE			HYPATITE® PTFE			HYPATITE® PTFE			HYPATITE® PTFE			HYPATITE® PTFE				
	Full Port			Full Port			Full Port			Full Port			Full Port				

Bronze & Brass

Cast Iron

Ductile Iron

Stainless Steel

Carbon Steel

Butterfly Valve

Ball Valve

Ball Valve Seal

Actuated Valve



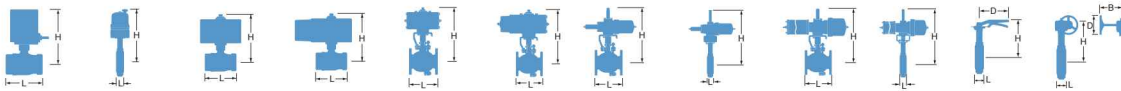

TYPE	FLOATING BALL					FLOATING BALL			BUTTERFLY			BUTTERFLY			BUTTERFLY		
Actuators Valves																	
FIG	FAS-300UTDZ					FAS-300UTDZM			FAS-10XJME			FAS-10DJ			FAS-10DJE		
PRESSURE	Class 300					Class 300			10K			10K			10K		
END CONNECTION	ASME B16.5					ASME B16.5			Wafer Type (JIS 5K,10K)			Wafer Type (JIS 5K,10K)			Wafer Type (JIS 5K,10K)		
DIMENSIONS	inch	mm	L	H	D	L	H	D	L	H	D	L	H	D	L	H	D
	1/2	15	140	215	—	140	215	—	—	—	—	—	—	—	—	—	—
	3/4	20	152	241	—	152	241	—	—	—	—	—	—	—	—	—	—
	1	25	165	276	—	165	276	—	—	—	—	—	—	—	—	—	—
	1 1/2	40	190	313	—	190	313	—	33	274	—	—	—	—	—	—	—
	2	50	216	355	—	216	355	—	43	278	—	43	293	—	43	293	—
	2 1/2	65	241	409	—	241	409	—	46	303	—	46	301	—	46	301	—
	3	80	283	475	—	283	475	—	46	311	—	46	335	—	46	335	—
	4	100	305	503	—	305	503	—	52	364	—	52	384	—	52	384	—
	5	125	—	—	—	—	—	—	56	396	—	56	412	—	56	412	—
	6	150	403	581	—	403	581	—	56	452	—	56	468	—	56	468	—
	8	200	—	—	—	—	—	—	60	508	—	60	522	—	60	522	—
	10	250	—	—	—	—	—	—	—	—	—	68	578	—	68	578	—
BODY	Stainless Steel					Stainless Steel			Aluminum Die-Cast			Ductile Iron			Ductile Iron		
BONNET	Stainless Steel					Stainless Steel			—			—			—		
STEM	Stainless Steel					Stainless Steel			Stainless Steel			Stainless Steel			Stainless Steel		
BALL / DISC	Stainless Steel					Stainless Steel			Stainless Steel			Ductile Iron+ENP			Ductile Iron+ENP		
SEAT	HYPATITE® PTFE					HYPATITE® PTFE			EPDM			NBR			EPDM		
	Full Port					Full Port			—			Ductile iron (Ni-plated) disc			Ductile iron (Ni-plated) disc		

TYPE	BUTTERFLY					FLOATING BALL			FLOATING BALL			3WAY FLOATING BALL			FLOATING BALL		
Actuators Valves																	
FIG	FAS-10LJF					B-10FCT			B-10FCTB			B-10FCTB2L			B-10STLBF		
PRESSURE	10K					10K			10K			10K			10K		
END CONNECTION	Wafer Type (JIS 10K)					BS21 (JIS B0203)			JIS B2239			JIS B2239			JIS B2239		
DIMENSIONS	inch	mm	L	H	D	L	H	D	L	H	D	L	H	D	L	H	D
	3/8	10	—	—	—	72	202	—	—	—	—	—	—	—	—	—	—
	1/2	15	—	—	—	80	212	—	110	212	—	—	—	—	108	216	—
	3/4	20	—	—	—	85	215	—	120	215	—	—	—	—	117	219	—
	1	25	—	—	—	95	222	—	130	222	—	—	—	—	127	227	—
	1 1/4	32	—	—	—	120	298	—	140	298	—	—	—	—	140	302	—
	1 1/2	40	—	—	—	120	318	—	165	318	—	210	318	—	165	318	—
	2	50	43	284	—	140	365	—	180	365	—	220	367	—	178	365	—
	2 1/2	65	46	334	—	160	390	—	190	390	—	250	392	—	190	390	—
	3	80	46	342	—	182	464	—	200	464	—	260	464	—	203	464	—
	4	100	52	391	—	—	—	—	230	487	—	330	491	—	229	487	—
	5	125	56	455	—	—	—	—	300	600	—	—	—	—	356	600	—
	6	150	56	468	—	—	—	—	340	625	—	—	—	—	394	625	—
	8	200	—	—	—	—	—	—	450	712	—	—	—	—	457	712	—
	10	250	—	—	—	—	—	—	533	772	—	—	—	—	—	—	—
BODY	Ductile Iron					Cast Iron			Cast Iron			Cast Iron			Ductile Iron		
BONNET	—					Cast Iron			Cast Iron			Cast Iron			Ductile Iron		
STEM	Stainless Steel					Stainless Steel			Stainless Steel			Stainless Steel			Stainless Steel		
BALL / DISC	Stainless Steel+PFA					Stainless Steel			Stainless Steel			Stainless Steel			Stainless Steel		
SEAT	—					PTFE			PTFE			PTFE			PTFE		
	Full Port					Full Port			Full Port			Full Port			Full Port		



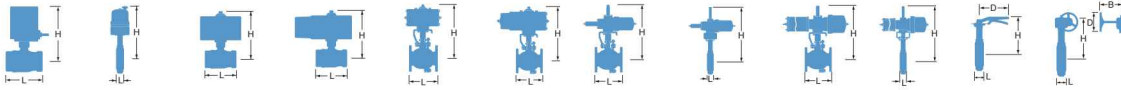

TYPE	FLOATING BALL			FLOATING BALL			FLOATING BALL			FLOATING BALL			3WAY FLOATING BALL					
Actuators Valves																		
FIG	B-10UT			B-10UTDZ			B-10UTDZM			B-10SCTDZ			B-10UTB2L					
PRESSURE	10K			10K			10K			10K			10K					
END CONNECTION	BS21 (JIS B0203)			JIS B2220			JIS B2220			JIS B2220			JIS B2220					
DIMENSIONS	inch	mm	L	H	D	L	H	D	L	H	D	L	H	D	L	H	D	
			3/8	10	62	202	-	-	-	-	-	-	-	-	-	-	-	-
	1/2	15	65	212	-	108	202	-	108	202	-	108	202	-	-	-	-	-
	3/4	20	80	215	-	117	205	-	117	205	-	117	205	-	-	-	-	-
	1	25	90	222	-	127	299	-	127	299	-	127	299	-	165	207	-	-
	1 1/4	32	110	298	-	140	303	-	140	303	-	-	-	-	-	-	-	-
	1 1/2	40	120	318	-	165	358	-	165	358	-	165	358	-	210	318	-	-
	2	50	140	365	-	178	367	-	178	367	-	178	367	-	220	367	-	-
	2 1/2	65	160	390	-	190	408	-	190	408	-	190	408	-	250	392	-	-
	3	80	182	464	-	203	470	-	203	470	-	203	470	-	260	464	-	-
4	100	-	-	-	229	498	-	229	498	-	229	498	-	330	491	-	-	
5	125	-	-	-	356	599	-	356	599	-	356	599	-	-	-	-	-	
6	150	-	-	-	394	632	-	394	632	-	394	632	-	-	-	-	-	
8	200	-	-	-	457	740	-	457	740	-	457	740	-	-	-	-	-	
10	250	-	-	-	533	783	-	533	783	-	533	783	-	-	-	-	-	
BODY	Stainless Steel			Stainless Steel			Stainless Steel			Cast Steel			Stainless Steel					
BONNET	Stainless Steel			Stainless Steel			Stainless Steel			Cast Steel			Stainless Steel					
STEM	Stainless Steel			Stainless Steel			Stainless Steel			Stainless Steel			Stainless Steel					
BALL	Stainless Steel			Stainless Steel			Stainless Steel			Stainless Steel			Stainless Steel					
SEAT	PTFE			HYPATITE® PTFE			HYPATITE® PTFE			HYPATITE® PTFE			HYPATITE® PTFE					
	Full Port			Full Port			Full Port			Full Port			Full Port					

TYPE	3WAY FLOATING BALL			FLOATING BALL			FLOATING BALL			FLOATING BALL			FLOATING BALL				
Actuators Valves																	
FIG	B-10UTB4LA			B-10UTBLN			B-150SCTDZ			B-150UTDZ			B-150UTDZM				
PRESSURE	10K			10K			Class 150			Class 150			Class 150				
END CONNECTION	JIS B2220			JIS B2220			ASME B16.5			ASME B16.5			ASME B16.5				
DIMENSIONS	inch	mm	L	H	D	L	H	D	L	H	D	L	H	D	L	H	D
			1/2	15	120	296	-	140	215	-	108	202	-	108	202	-	108
	3/4	20	140	299	-	152	217	-	117	205	-	117	205	-	117	205	-
	1	25	160	303	-	165	227	-	127	299	-	127	299	-	127	299	-
	1 1/4	32	-	-	-	-	-	-	-	-	-	140	303	-	140	303	-
	1 1/2	40	180	380	-	191	322	-	165	358	-	165	358	-	165	358	-
	2	50	200	454	-	216	368	-	178	367	-	178	367	-	178	367	-
	2 1/2	65	240	473	-	240	392	-	190	408	-	190	408	-	190	408	-
	3	80	260	578	-	250	467	-	203	470	-	203	470	-	203	470	-
	4	100	330	600	-	280	493	-	229	498	-	229	498	-	229	498	-
5	125	-	-	-	-	-	-	356	599	-	356	599	-	356	599	-	
6	150	-	-	-	-	-	-	394	632	-	394	632	-	394	632	-	
8	200	-	-	-	-	-	-	457	740	-	457	740	-	457	740	-	
10	250	-	-	-	-	-	-	533	783	-	533	783	-	533	783	-	
BODY	Stainless Steel			Stainless Steel			Cast Steel			Stainless Steel			Stainless Steel				
BONNET	Stainless Steel			Stainless Steel			Cast Steel			Stainless Steel			Stainless Steel				
STEM	Stainless Steel			Stainless Steel			Stainless Steel			Stainless Steel			Stainless Steel				
BALL	Stainless Steel			Stainless Steel			Stainless Steel			Stainless Steel			Stainless Steel				
SEAT	HYPATITE® PTFE			HYPATITE® PTFE			HYPATITE® PTFE			HYPATITE® PTFE			HYPATITE® PTFE				
	Full Port			Full Port			Full Port			Full Port			Full Port				

Bronze & Brass

Cast Iron

Ductile Iron

Stainless Steel

Carbon Steel

Butterfly Valve

Ball Valve

Ball Valve Seat

Actuated Valve

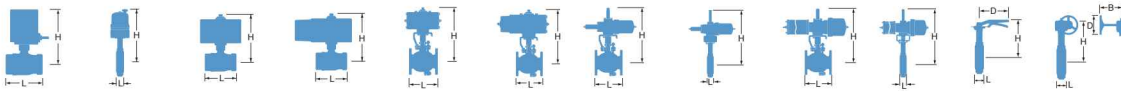

TYPE		FLOATING BALL			FLOATING BALL			FLOATING BALL			FLOATING BALL			FLOATING BALL			
Actuators Valves																	
FIG		B-20SCTDZ			B-20UTDZ			B-20UTDZM			B-300SCTDZ			B-300UTDZ			
PRESSURE		20K			20K			20K			Class 300			Class 300			
END CONNECTION		JIS B2220			JIS B2220			JIS B2220			ASME B16.5			ASME B16.5			
DIMENSIONS	inch	mm	L	H	D	L	H	D	L	H	D	L	H	D	L	H	D
	1/2	15	140	202	—	140	202	—	140	202	—	140	202	—	140	202	—
	3/4	20	152	205	—	152	205	—	152	205	—	152	205	—	152	205	—
	1	25	165	299	—	165	299	—	165	299	—	165	299	—	165	299	—
	1 1/4	32	—	—	—	178	303	—	178	303	—	—	—	—	—	—	—
	1 1/2	40	190	358	—	190	358	—	190	358	—	190	358	—	190	358	—
	2	50	216	367	—	216	367	—	216	367	—	216	367	—	216	367	—
	2 1/2	65	241	408	—	241	408	—	241	408	—	241	408	—	241	408	—
	3	80	283	470	—	283	470	—	283	470	—	283	470	—	283	470	—
	4	100	305	498	—	305	498	—	305	498	—	305	498	—	305	498	—
	5	125	381	599	—	381	599	—	381	599	—	—	—	—	—	—	—
	6	150	403	632	—	403	632	—	403	632	—	403	632	—	403	632	—
	8	200	502	740	—	502	740	—	502	740	—	502	740	—	502	740	—
BODY		Cast Steel			Stainless Steel			Stainless Steel			Cast Steel			Stainless Steel			
BONNET		Cast Steel			Stainless Steel			Stainless Steel			Cast Steel			Stainless Steel			
STEM		Stainless Steel			Stainless Steel			Stainless Steel			Stainless Steel			Stainless Steel			
BALL		Stainless Steel			Stainless Steel			Stainless Steel			Stainless Steel			Stainless Steel			
SEAT		HYPATITE® PTFE			HYPATITE® PTFE			HYPATITE® PTFE			HYPATITE® PTFE			HYPATITE® PTFE			
		Full Port			Full Port			Full Port			Full Port			Full Port			

TYPE		FLOATING BALL			BUTTERFLY			BUTTERFLY			BUTTERFLY			FLOATING BALL			
Actuators Valves																	
FIG		B-300UTDZM			B-10DJ			B-10DJE			B-10LJF			BS-10FCT			
PRESSURE		Class 300			10K			10K			10K			10K			
END CONNECTION		ASME B16.5			Wafer Type (JIS 5K,10K)			Wafer Type (JIS 5K,10K)			Wafer Type (JIS 10K)			BS21 (JIS B0203)			
DIMENSIONS	inch	mm	L	H	D	L	H	D	L	H	D	L	H	D	L	H	D
	3/8	10	—	—	—	—	—	—	—	—	—	—	—	—	72	202	—
	1/2	15	140	202	—	—	—	—	—	—	—	—	—	—	80	212	—
	3/4	20	152	205	—	—	—	—	—	—	—	—	—	—	85	215	—
	1	25	165	299	—	—	—	—	—	—	—	—	—	—	95	222	—
	1 1/4	32	—	—	—	—	—	—	—	—	—	—	—	—	120	298	—
	1 1/2	40	190	358	—	—	—	—	—	—	—	—	—	—	120	318	—
	2	50	216	367	—	43	374	—	43	374	—	43	369	—	140	365	—
	2 1/2	65	241	408	—	46	382	—	46	382	—	46	397	—	—	—	—
	3	80	283	470	—	46	420	—	46	420	—	46	404	—	182	464	—
	4	100	305	498	—	52	445	—	52	445	—	52	469	—	—	—	—
	5	125	—	—	—	56	473	—	56	473	—	56	504	—	—	—	—
	6	150	403	632	—	56	485	—	56	485	—	56	600	—	—	—	—
	8	200	502	740	—	60	570	—	60	570	—	60	634	—	—	—	—
	10	250	—	—	—	68	709	—	68	709	—	68	736	—	—	—	—
	12	300	—	—	—	78	734	—	78	734	—	78	761	—	—	—	—
BODY		Stainless Steel			Ductile Iron			Ductile Iron			Ductile Iron			Cast Iron			
BONNET		Stainless Steel			—			—			—			Cast Iron			
STEM		Stainless Steel			Stainless Steel			Stainless Steel			Stainless Steel			Stainless Steel			
BALL / DISC		Stainless Steel			Ductile Iron+ENP			Ductile Iron+ENP			Stainless Steel+PFA			Stainless Steel			
SEAT		HYPATITE® PTFE			NBR			EPDM			—			PTFE			
		Full Port			Ductile iron (Ni-plated) disc			Ductile iron (Ni-plated) disc						Full Port			

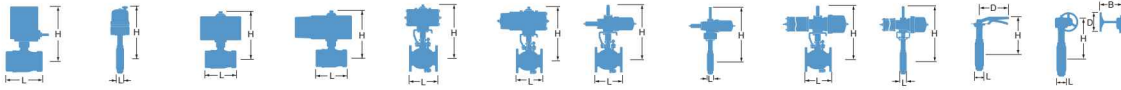

TYPE	FLOATING BALL					3WAY FLOATING BALL			FLOATING BALL			FLOATING BALL			FLOATING BALL			
Actuators Valves																		
FIG	BS-10FCTB					BS-10FCTB2L			BS-10STLBF			BS-10UT			BS-10UTDZ			
PRESSURE	10K					10K			10K			10K			10K			
END CONNECTION	JIS B2239					JIS B2239			JIS B2239			BS21 (JIS B0203)			JIS B2220			
DIMENSIONS	inch	mm	L	H	D	L	H	D	L	H	D	L	H	D	L	H	D	
			3/8	10	-	-	-	-	-	-	-	-	-	62	202	-	-	-
	1/2	15	110	212	-	-	-	-	108	216	-	-	65	212	-	108	202	-
	3/4	20	120	215	-	-	-	-	117	219	-	-	80	215	-	117	205	-
	1	25	130	222	-	-	-	-	127	227	-	-	90	222	-	127	299	-
	1 1/4	32	140	298	-	-	-	-	140	302	-	-	110	298	-	140	303	-
	1 1/2	40	165	318	-	210	318	-	165	318	-	-	120	318	-	165	358	-
	2	50	180	365	-	220	367	-	178	365	-	-	140	365	-	178	367	-
	2 1/2	65	190	390	-	250	392	-	190	390	-	-	160	390	-	190	408	-
	3	80	200	464	-	260	464	-	203	464	-	-	182	464	-	203	470	-
4	100	230	487	-	330	491	-	229	487	-	-	-	-	-	229	498	-	
5	125	300	600	-	-	-	-	356	600	-	-	-	-	-	356	599	-	
6	150	340	625	-	-	-	-	394	625	-	-	-	-	-	394	632	-	
8	200	450	712	-	-	-	-	457	712	-	-	-	-	-	457	740	-	
10	250	533	772	-	-	-	-	-	-	-	-	-	-	-	533	792	-	
BODY	Cast Iron					Cast Iron			Ductile Iron			Stainless Steel			Stainless Steel			
BONNET	Cast Iron					Cast Iron			Ductile Iron			Stainless Steel			Stainless Steel			
STEM	Stainless Steel					Stainless Steel			Stainless Steel			Stainless Steel			Stainless Steel			
BALL	Stainless Steel					Stainless Steel			Stainless Steel			Stainless Steel			Stainless Steel			
SEAT	PTFE					PTFE			PTFE			PTFE			HYPATITE® PTFE			
	Full Port					Full Port			Full Port			Full Port			Full Port			

TYPE	FLOATING BALL					FLOATING BALL			3WAY FLOATING BALL			3WAY FLOATING BALL			FLOATING BALL		
Actuators Valves																	
FIG	BS-10UTDZM					BS-10SCTDZ			BS-10UTB2L			BS-10UTB4LA			BS-10UTBLN		
PRESSURE	10K					10K			10K			10K			10K		
END CONNECTION	JIS B2220					JIS B2220			JIS B2220			JIS B2220			JIS B2220		
DIMENSIONS	inch	mm	L	H	D	L	H	D	L	H	D	L	H	D	L	H	D
			1/2	15	108	202	-	108	202	-	-	-	-	120	296	-	140
	3/4	20	117	205	-	117	205	-	-	-	-	140	299	-	152	217	-
	1	25	127	299	-	127	299	-	165	207	-	160	303	-	165	227	-
	1 1/4	32	140	303	-	-	-	-	-	-	-	-	-	-	-	-	-
	1 1/2	40	165	358	-	165	358	-	210	318	-	180	380	-	191	322	-
	2	50	178	367	-	178	367	-	220	367	-	200	454	-	216	368	-
	2 1/2	65	190	408	-	190	408	-	250	392	-	240	473	-	240	392	-
	3	80	203	470	-	203	470	-	260	464	-	260	578	-	250	467	-
	4	100	229	498	-	229	498	-	330	491	-	330	600	-	280	493	-
5	125	356	599	-	356	599	-	-	-	-	-	-	-	-	-	-	
6	150	394	632	-	394	632	-	-	-	-	-	-	-	-	-	-	
8	200	457	740	-	457	740	-	-	-	-	-	-	-	-	-	-	
10	250	533	792	-	533	792	-	-	-	-	-	-	-	-	-	-	
BODY	Stainless Steel					Cast Steel			Stainless Steel			Stainless Steel			Stainless Steel		
BONNET	Stainless Steel					Cast Steel			Stainless Steel			Stainless Steel			Stainless Steel		
STEM	Stainless Steel					Stainless Steel			Stainless Steel			Stainless Steel			Stainless Steel		
BALL	Stainless Steel					Stainless Steel			Stainless Steel			Stainless Steel			Stainless Steel		
SEAT	HYPATITE® PTFE					HYPATITE® PTFE			HYPATITE® PTFE			HYPATITE® PTFE			HYPATITE® PTFE		
	Full Port					Full Port			Full Port			Full Port			Full Port		

Bronze & Brass  
 Cast Iron  
 Ductile Iron  
 Stainless Steel  
 Carbon Steel  
 Butterfly Valve  
 Ball Valve  
 Ball Valve Seal  
 Actuated Valve



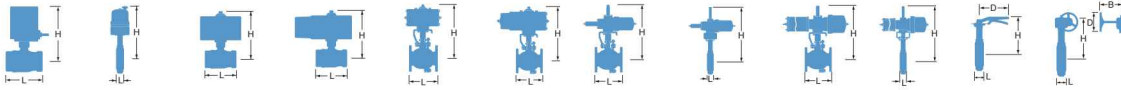

TYPE	LAMBDA PORT					FLOATING BALL			FLOATING BALL			FLOATING BALL			FLOATING BALL		
Actuators Valves																	
FIG	BS-10UVC					BS-150SCTDZ			BS-150UTDZ			BS-20SCTDZ			BS-20UTDZ		
PRESSURE	10K					Class 150			Class 150			20K			20K		
END CONNECTION	JIS B2220					ASME B16.5			ASME B16.5			JIS B2220			JIS B2220		
DIMENSIONS	inch	mm	L	H	D	L	H	D	L	H	D	L	H	D	L	H	D
	1/2	15	—	—	—	108	202	—	108	202	—	140	202	—	140	202	—
	3/4	20	—	—	—	117	205	—	117	205	—	152	205	—	152	205	—
	1	25	127	306	—	127	299	—	127	299	—	165	299	—	165	299	—
	1 1/4	32	—	—	—	—	—	—	140	303	—	—	—	—	178	303	—
	1 1/2	40	165	369	—	165	358	—	165	358	—	190	358	—	190	358	—
	2	50	178	375.5	—	178	367	—	178	367	—	216	367	—	216	367	—
	2 1/2	65	190	459.5	—	190	408	—	190	408	—	241	408	—	241	408	—
	3	80	203	466	—	203	470	—	203	470	—	283	470	—	283	470	—
	4	100	229	493	—	229	498	—	229	498	—	305	498	—	305	498	—
	5	125	—	—	—	356	599	—	356	599	—	381	599	—	381	599	—
	6	150	394	638	—	394	632	—	394	632	—	403	632	—	403	632	—
	8	200	457	727	—	457	740	—	457	740	—	502	740	—	502	740	—
	10	250	533	751	—	533	792	—	533	792	—	—	—	—	—	—	—
BODY	Stainless Steel					Cast Steel			Stainless Steel			Cast Steel			Stainless Steel		
BONNET	Stainless Steel					Cast Steel			Stainless Steel			Cast Steel			Stainless Steel		
STEM	Stainless Steel					Stainless Steel			Stainless Steel			Stainless Steel			Stainless Steel		
BALL	Stainless Steel					Stainless Steel			Stainless Steel			Stainless Steel			Stainless Steel		
SEAT	—					HYPATITE® PTFE			HYPATITE® PTFE			HYPATITE® PTFE			HYPATITE® PTFE		
	Full Port					Full Port			Full Port			Full Port			Full Port		

TYPE	FLOATING BALL					FLOATING BALL			FLOATING BALL			FLOATING BALL			BUTTERFLY		
Actuators Valves																	
FIG	BS-20UTDZM					BS-300SCTDZ			BS-300UTDZ			BS-300UTDZM			BS-10DJ		
PRESSURE	20K					Class 300			Class 300			Class 300			10K		
END CONNECTION	JIS B2220					ASME B16.5			ASME B16.5			ASME B16.5			Wafer Type (JIS 5K,10K)		
DIMENSIONS	inch	mm	L	H	D	L	H	D	L	H	D	L	H	D	L	H	D
	1/2	15	140	202	—	140	202	—	140	202	—	140	202	—	—	—	—
	3/4	20	152	205	—	152	205	—	152	205	—	152	205	—	—	—	—
	1	25	165	299	—	165	299	—	165	299	—	165	299	—	—	—	—
	1 1/4	32	178	303	—	—	—	—	—	—	—	—	—	—	—	—	—
	1 1/2	40	190	358	—	190	358	—	190	358	—	190	358	—	43	374	—
	2	50	216	367	—	216	367	—	216	367	—	216	367	—	46	382	—
	2 1/2	65	241	408	—	241	408	—	241	408	—	241	408	—	46	435	—
	3	80	283	470	—	283	470	—	283	470	—	283	470	—	52	445	—
	4	100	305	498	—	305	498	—	305	498	—	305	498	—	56	473	—
	5	125	381	599	—	—	—	—	403	632	—	403	632	—	56	545	—
	6	150	403	632	—	403	632	—	502	740	—	502	740	—	60	570	—
	8	200	502	740	—	502	740	—	—	—	—	—	—	—	68	709	—
	10	250	—	—	—	—	—	—	—	—	—	—	—	—	78	734	—
BODY	Stainless Steel					Cast Steel			Stainless Steel			Stainless Steel			Ductile Iron		
BONNET	Stainless Steel					Cast Steel			Stainless Steel			Stainless Steel			—		
STEM	Stainless Steel					Stainless Steel			Stainless Steel			Stainless Steel			Stainless Steel		
BALL / DISC	Stainless Steel					Stainless Steel			Stainless Steel			Stainless Steel			Ductile Iron+ENP		
SEAT	HYPATITE® PTFE					HYPATITE® PTFE			HYPATITE® PTFE			HYPATITE® PTFE			NBR		
	Full Port					Full Port			Full Port			Full Port			Ductile iron (Ni-plated) disc		



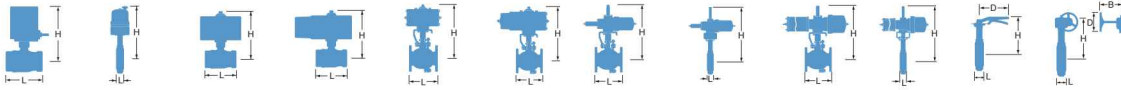

TYPE		BUTTERFLY				BUTTERFLY			BUTTERFLY			
Actuators Valves						NO IMAGE			NO IMAGE			
FIG		BS-10DJE				BS-10LJF			BSW-10LJF			
PRESSURE		10K				10K			10K			
END CONNECTION		Wafer Type (JIS 5K,10K)				Wafer Type (JIS 10K)			Wafer Type (JIS 10K)			
DIMENSIONS		inch	mm	L	H	D	L	H	D	L	H	D
	1½	40	43	374	—	—	—	—	—	—	—	—
	2	50	46	382	—	43	384	—	43	384	—	—
	2½	65	46	435	—	46	397	—	46	397	—	—
	3	80	52	445	—	46	464	—	46	464	—	—
	4	100	56	473	—	52	469	—	52	469	—	—
	5	125	56	545	—	56	504	—	56	504	—	—
	6	150	60	570	—	56	600	—	56	600	—	—
	8	200	68	709	—	60	634	—	60	634	—	—
	10	250	78	734	—	68	736	—	68	736	—	—
	12	300	—	—	—	78	761	—	78	761	—	—
BODY		Ductile Iron				Ductile Iron			Ductile Iron			
STEM		Stainless Steel				Stainless Steel			Stainless Steel			
BALL / DISC		Ductile Iron+ENP				Stainless Steel+PFA			Stainless Steel+PFA			
SEAT		EPDM				—			—			
		Ductile iron (Ni-plated) disc										

Brass & Bronze

Cast Iron

Ductile Iron

Stainless Steel

Carbon Steel

Butterfly Valve

Ball Valve

Ball Valve Seat

Actuated Valve

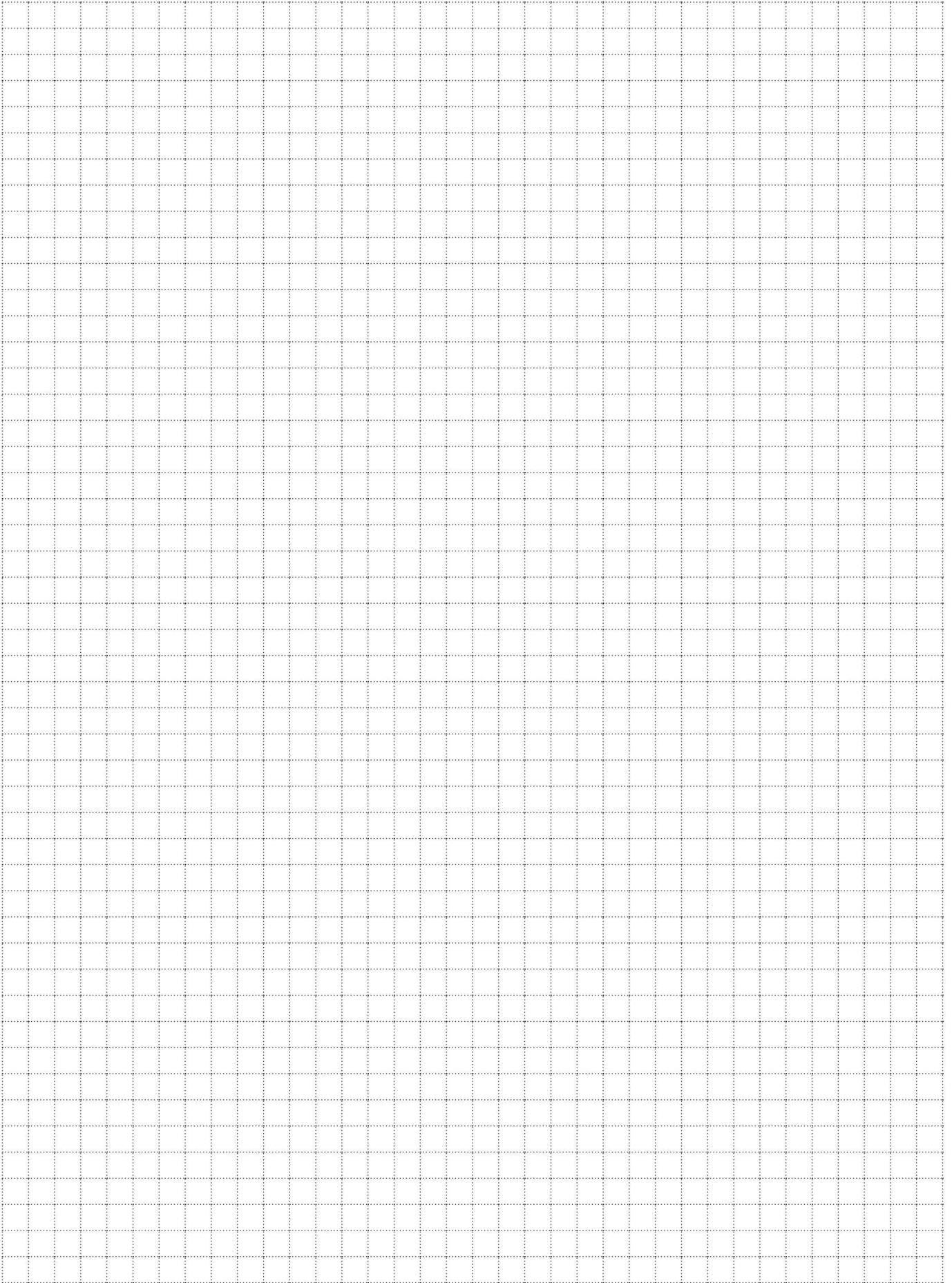



## CAUTION

Pressure-temperature ratings and other performance data published in this catalog have been developed from our design calculation, in-house testing, field reports provided by our customers and/or published official standards or specifications. They are good only to cover typical applications as a general guideline to users of KITZ products introduced in this catalog.

For any specific application, users are kindly requested to contact KITZ Corporation for technical advice, or to carry out their own study and evaluation for proving the suitability of these products to such an application. Failure to follow this request could result in property damage and/or personal injury, for which we shall not be liable.

While this catalog has been compiled with the utmost care, we assume no responsibility for errors, impropriety, or inadequacy. Any information provided in this catalog is subject to from-time-to-time change without notice for error rectification, product discontinuation, design modification, new product introduction, or any other cause that KITZ Corporation considers necessary. This edition cancels all previous issues.

Read the instruction manual carefully before use.

## NOTICE

If any products designated as strategic material in the Foreign Exchange and Foreign Trade Law, Cabinet Order Concerning Control of Export Trade, Cabinet Order Concerning Control of Foreign Exchange, and other related laws and ordinances ("Foreign Exchange Laws") are exported to any foreign country or countries, an export license issued by the Japanese Government will be required under the Foreign Exchange Laws.

Further, there may be cases where an export license issued by the government of the United States or other country will be required under the applicable export-related laws and ordinances in such relevant countries.

The contract shall become effective subject to the fact that a relevant export license is obtained from the Japanese Government.

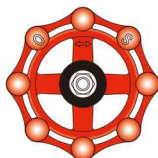

*A chrysanthemum-handle is a symbol of KITZ,  
the brand of valve reliability*

ISO 9001 certified since 1989

**KITZ**  
KITZ CORPORATION

1-10-1 Nakase, Mihama-ku, Chiba 261-8577, Japan  
International Sales Dept.  
Phone : 81-43-299-1730  
Fax : 81-43-299-0121

— Distributed by —